

# EPSON® ESC/I™ Scanner

**GT-1000**

**GT-4000**

**GT-6000**

**GT-6500**

**GT-8000**

**GT-8500**

**GT-9000**

**GT-5000**

**GT-300**

**ES-300C**

**ES-600C**

**ES-800C**

**ES-1000C**

**ES-1200C**

**Action Scanner II**

**ES-300GS**

Reference Manual

---

All rights reserved. No part of this publication may be reproduced, stored in a retrieval system, or transmitted in any form or any means, electronic, mechanical, photocopying, recording, or otherwise, without the prior written permission of Seiko Epson Corporation. No patent liability is assumed with respect to the use of the information contained herein. While every precaution has been taken in the preparation of this book, Seiko Epson Corporation assumes no responsibility for errors or omissions. Neither is any liability assumed for damages resulting from the use of the information contained herein.

Seiko Epson Corporation shall not be liable against any damages or problems arising from the use of any options other than those designated as Original Epson Products by Seiko Epson Corporation.

EPSON is a registered trademark of Seiko Epson Corporation.

EPSON ESC/I is a trademark of Seiko Epson Corporation.

HP PaintJet is a trademark of Hewlett-Packard Company.

Apple and Macintosh are trademarks of Apple Computer, Inc.

Copyright © 1995 by Seiko Epson Corporation, Nagano, Japan.

---

# ***Preface***

This manual was designed to be a comprehensive guide to programming EPSON scanners using the advanced ESC/I control language. It was written with both the professional and advanced hobbyist programmer in mind.

Before you begin using this manual, you should thoroughly review the operating instructions in your scanner's user's guide.



---

# Contents

## **Introduction**

---

Manual Construction . . . . .	2
Overview . . . . .	2
Command Usage . . . . .	2
Command Reference . . . . .	2
Appendix . . . . .	2
Using This Manual . . . . .	3
To understand EPSON scanners . . . . .	3
To write a scanner control program . . . . .	3

## **Chapter 1 Overview**

---

What Is a Scanner . . . . .	1-2
Basic scanning principles . . . . .	1-2
Reading color . . . . .	1-4
Reading monochrome . . . . .	1-4
EPSON Scanner Features . . . . .	1-5
Control Code Construction . . . . .	1-7
Function level . . . . .	1-7
Parameters . . . . .	1-7
Computers and Handshaking . . . . .	1-8
Image Data . . . . .	1-9
Image data format . . . . .	1-9
Line data transfer . . . . .	1-11
Block data transfer . . . . .	1-12
Functions . . . . .	1-13
Image definition . . . . .	1-13
Gamma correction . . . . .	1-14
Data form definition . . . . .	1-16
Image processing . . . . .	1-21

Using Scanner Features . . . . .	1-23
Scanning multiple shade documents for output on devices capable of expressing multiple shades. . . . .	1-23
Scanning multiple shade documents for bi-level output devices capable of black and white only . . . . .	1-24
Scanning documents without multiple shades . . . . .	1-24
Scanning documents to obtain unprocessed data . . . . .	1-24

**Chapter 2 Command Usage**

---

Execution Commands . . . . .	2-2
1. Start scanning (ESC G) . . . . .	2-2
2. Request ID (ESC I) . . . . .	2-3
3. Request Status (ESC F) . . . . .	2-3
4. Extended Status Request (ESC f) . . . . .	2-3
5. Request condition (ESC S) . . . . .	2-4
Data Form Commands . . . . .	2-5
1. Set Color Mode (ESC C) . . . . .	2-5
2. Set Data Format (ESC D) . . . . .	2-5
3. Set Resolution (ESC R) . . . . .	2-7
4. Set zoom (ESC H) . . . . .	2-7
5. Set scanning area (ESC A) . . . . .	2-8
6. Set data order (ESC K) . . . . .	2-8
Image Setting Commands . . . . .	2-9
1. Set brightness (ESC L) . . . . .	2-9
2. Set gamma correction (ESC Z) . . . . .	2-10
3. Download gamma table (ESC z) . . . . .	2-12
Image Processing Commands . . . . .	2-13
1. Set halftoning mode (ESC B) . . . . .	2-13
2. Download dither pattern (ESC b) . . . . .	2-15
3. Set color correction (ESC M) . . . . .	2-16
4. Download color correction (ESC m) . . . . .	2-17

Auxiliary Commands . . . . .	2-18
1. Initialize the scanner (ESC @) . . . . .	2-18
2. Set the scanning mode (ESC g) . . . . .	2-18
3. Set the line counter (ESC d) . . . . .	2-19
4. Control option (ESC e) . . . . .	2-20
5. Eject (FF) . . . . .	2-20
Control Codes . . . . .	2-20
1. Header (STX) . . . . .	2-20
2. Abort scanning (CAN) . . . . .	2-21
3. Normal response (ACK) . . . . .	2-21
4. Negative response (NAK) . . . . .	2-21
Command Order . . . . .	2-22
ID information . . . . .	2-22
Control flow . . . . .	2-23
Recommended command order . . . . .	2-24
Using commands when options are installed . . . . .	2-24
Data Block Transfer Order . . . . .	2-26
Data block structure . . . . .	2-26
Information block . . . . .	2-27
Data . . . . .	2-30
Transfer order . . . . .	2-32
Scanning Area . . . . .	2-35
Resolution, zoom, and maximum scannable area . . . . .	2-36
Setting the scanning area . . . . .	2-38
Image trimming (1) . . . . .	2-40
Image trimming (2) . . . . .	2-42
Error Processing . . . . .	2-44
Command error . . . . .	2-44
Communications error . . . . .	2-44
System error . . . . .	2-45
Option error . . . . .	2-46
Function Level and Commands . . . . .	2-47
Using the function level . . . . .	2-47
Commands and function level table . . . . .	2-48
Items not affected by function level . . . . .	2-50
Typical Programming Errors and Solutions . . . . .	2-51

*Chapter 3*    **Command Reference**

---

Summary of the Scanner Commands . . . . .	3-2
Format of the Command Reference . . . . .	3-4
Execution Commands . . . . .	3-6
Data Form Definition Commands . . . . .	3-18
Image Definition Commands . . . . .	3-36
Image Processing Commands . . . . .	3-45
Auxiliary Commands . . . . .	3-57
Control Codes . . . . .	3-65

*Appendix A*    **Interface Specifications**

---

Serial Interface Specifications . . . . .	A-2
Signal pin assignments . . . . .	A-3
Cable wiring . . . . .	A-3
Parallel Interface Specifications . . . . .	A-4
Signal pin assignments . . . . .	A-5
Timing charts . . . . .	A-7
SCSI Interface Specifications . . . . .	A-8
Basic Specification . . . . .	A-8
SCSI Operation Procedure . . . . .	A-13
Communication Operation . . . . .	A-13
SCSI Commands . . . . .	A-15
Unit Attention Condition . . . . .	A-16
Sense Data . . . . .	A-17
Initialization . . . . .	A-19
Default settings . . . . .	A-19



*Appendix B Scanner Model Technical Data*

---

GT-1000 Technical Data . . . . .	B-2
Physical Characteristics . . . . .	B-2
Error Indications . . . . .	B-2
Software Functions and Settings . . . . .	B-3
Software Defaults . . . . .	B-3
DIP Switch Setting . . . . .	B-4
The Identity Data-Block . . . . .	B-6
The Condition Data-Block . . . . .	B-7
GT-4000 Technical Data . . . . .	B-9
Physical Characteristics . . . . .	B-9
Error Indications . . . . .	B-9
Software Functions and Settings . . . . .	B-10
Software Defaults . . . . .	B-11
DIP Switch Setting . . . . .	B-12
The Identity Data-Block . . . . .	B-15
The Condition Data-Block . . . . .	B-17
GT-6000 (ES-300C) Technical Data . . . . .	B-19
Physical Characteristics . . . . .	B-19
Error Indications . . . . .	B-19
Software Functions and Settings . . . . .	B-20
Software Defaults . . . . .	B-21
DIP Switch Setting . . . . .	B-22
The Identity Data-Block . . . . .	B-25
The Condition Data-Block . . . . .	B-28
GT-6500 (ES-600C) Technical Data . . . . .	B-30
Physical Characteristics . . . . .	B-30
Error Indications . . . . .	B-31
Software Functions and Settings . . . . .	B-32
Software Defaults . . . . .	B-33
DIP Switch Setting . . . . .	B-34
The Identity Data-Block . . . . .	B-38
The Condition Data-Block . . . . .	B-41

GT-8000 (ES-800C) Technical Data . . . . .	B-43
Physical Characteristics . . . . .	B-43
Error Indications . . . . .	B-43
Software Functions and Settings . . . . .	B-44
Software Defaults . . . . .	B-45
The Identity Data-Block . . . . .	B-46
The Condition Data-Block . . . . .	B-49
GT-8500 (ES-1000C) Technical Data . . . . .	B-51
Physical Characteristics . . . . .	B-51
Error Indications . . . . .	B-51
Software Functions and Settings . . . . .	B-52
Software Defaults . . . . .	B-53
The Identity Data-Block . . . . .	B-54
The Condition Data-Block . . . . .	B-57
GT-9000 (ES-1200C) Technical Data . . . . .	B-60
Physical Characteristics . . . . .	B-60
Error Indications . . . . .	B-60
Software Functions and Settings . . . . .	B-61
Software Defaults . . . . .	B-62
The Identity Data-Block . . . . .	B-63
The Condition Data-Block . . . . .	B-67
GT-5000 (Action Scanner II) Technical Data . . . . .	B-69
Physical Characteristics . . . . .	B-69
Error Indications . . . . .	B-69
Software Functions and Settings . . . . .	B-70
Software Defaults . . . . .	B-71
The Identity Data-Block . . . . .	B-72
The Condition Data-Block . . . . .	B-75
GT-300 (ES-300GS) Technical Data . . . . .	B-78
Physical Characteristics . . . . .	B-78
Error Indications . . . . .	B-78
Software Functions and Settings . . . . .	B-79
Software Defaults . . . . .	B-80
The Identity Data-Block . . . . .	B-81
The Condition Data-Block . . . . .	B-84

---

# ***Introduction***

---

## ***Manual Construction***

This manual consists of the following sections:

- Overview
- Command Usage
- Command Reference
- Appendix

The contents of each of these sections is described below:

### ***Overview***

Presents an overview of scanner functions, EPSON scanner features, control codes, and programming concepts. This information is helpful in quickly understanding scanner operating concepts.

### ***Command Usage***

Provides recommended ESC/I command usage and program construction for optimum use of EPSON scanner features. This section also provides information on image data transfer, the scanning environment, and error handling.

### ***Command Reference***

Lists each ESC/I command and its parameters in detail.

### ***Appendix***

Offers additional information necessary for writing scanner programs. This includes the specifications for each type of interface, command support levels, and available scanner options.

---

## ***Using This Manual***

To get the most out of this manual, you should follow the steps below:

### ***To understand EPSON scanners***

Read through the overview once, and then read the Command Usage section in depth.

### ***To write a scanner control program***

Read through the overview once, then read the Command Usage section. From there, move to the Command Reference section, followed by the Appendix.

Always refer to the Appendix to ensure that the interface and data types correspond to your target scanner models.

Also, several examples of common programming errors and information on resolving these errors are included.



## **Overview**

This chapter provides a brief description of scanner operations and concepts. The special features of EPSON brand scanners are also outlined in this chapter.

---

## ***What Is a Scanner***

A scanner is a device that performs the following functions:

- ❑ Reflects light off your documents
- ❑ Separates the light by color and intensity
- ❑ Converts that reflected light to digital data
- ❑ Sends the digital data to your computer for further processing

### ***Basic scanning principles***

A scanner normally includes two components: a light source that illuminates the document and a sensor that detects the light reflected off the document. The sensor is composed of CCD element arrays that detect the brightness of the reflected light and produce corresponding digital signals.

The document is read by a horizontal row of sensors that move vertically down the page. Data from the sensors is read at regular intervals (such as 300 times per inch), achieving very high resolutions.

Data is organized horizontally and vertically; the scanning direction is referred to by the following terms:



## **Main scan**

The horizontal scanning direction

## **Sub scan**

The vertical scanning direction

By combining the main scan and sub scan data, an entire page can be converted into organized digital data.

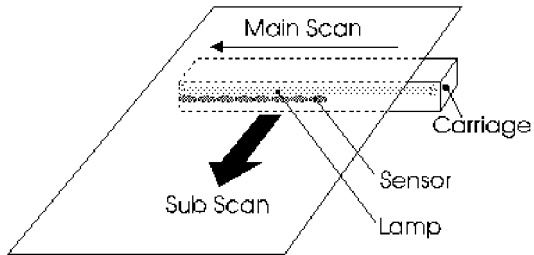

## ***Reading color***

By illuminating the document with three lights, red (R), green (G), and blue (B), the scanner can analyze and separate a document's three color components. The computer can then overlay this color-separated data to produce full-color images.

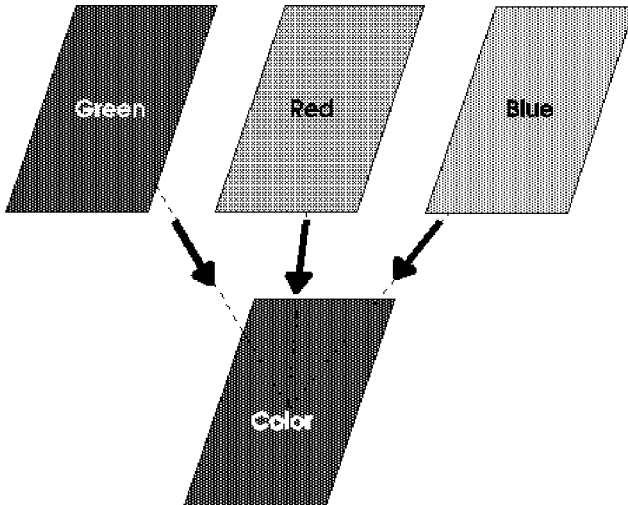

## ***Reading monochrome***

Even though you have a color scanner, you can still read your documents as monochrome. Color scanners can read documents as monochrome in two ways:

- ❑ Treat all the data on the page as the same color. This method uses all the light sources, and is fine if you plan to print data in black and white only.
- ❑ Specify one color (R, G, or B) as a dropout color. This method uses only one light source and reads all data except for the color specified.

---

# EPSON Scanner Features

EPSON scanners feature the following special attributes.

❑ A unified control code structure

All scanner features are controlled by EPSON's ESC/I scanner control codes, so the commands for each feature are the same for all scanner models. All models are downwardly compatible, so programs written for lower level scanners will work identically on upper level scanners.

❑ Internal image data processing circuits

Each scanner contains circuitry capable of processing image data before it is sent to the computer; the type of processing is specified by control codes. By preprocessing image data, the computer can process data faster with a reduction in image distortion.

❑ Support of various interfaces

GT-1000:	RS-232C Serial, Bi-directional Parallel
GT-4000:	RS-232C Serial, Bi-directional Parallel, SCSI (option)
GT-6000:	RS-232C Serial, Bi-directional Parallel, SCSI (option)
GT-8000:	Bi-directional Parallel, SCSI
GT-6500:	RS-232C Serial, Bi-directional Parallel, SCSI
GT-8500:	Bi-directional Parallel, SCSI
GT-9000:	Bi-directional Parallel, SCSI
GT-300:	Bi-directional Parallel, SCSI
GT-5000:	Bi-directional Parallel, SCSI
ES-300C:	RS-232C Serial, Bi-directional Parallel, SCSI (option)
ES-600C:	Bi-directional Parallel, SCSI
ES-800C:	Bi-directional Parallel, SCSI
ES-1000C:	Bi-directional Parallel, SCSI
ES-1200C:	Bi-directional Parallel, SCSI
ES-300GS:	Bi-directional Parallel, SCSI
Action Scanner II	Bi-directional Parallel, SCSI

❑ Optional automatic document feeder

An automatic document feeder can be mounted on the GT-8000 (ES-800C), GT-6500 (ES-600C), GT-8500 (ES-1000C), or GT-9000 (ES-1200C) scanner models, allowing you to automatically load and scan multiple documents. This is particularly useful when using OCR (Optical Character Recognition) software to input text from long documents, or when creating an image data base.

❑ Optional transparency illumination unit

This unit can read transparencies (film) when mounted on the GT-8000 (ES-800C), GT-6500 (ES-600C), GT-8500 (ES-1000C), or GT-9000 (ES-1200C) models. You can now scan film directly, without having to first make a print of the film as was necessary in the past. This allows for more accurate reading of film colors with a minimum of degradation in image resolution. You can also now directly read documents stored on film.

---

# Control Code Construction

## Function level

The EPSON image scanner control language currently has the following function levels: B1 to B5 and A5. The relationship of each level is shown in the following diagram. Each level contains the commands and features of all lower levels.

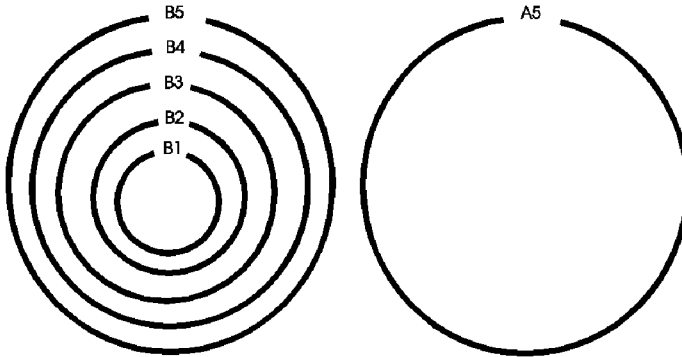

For example, if you are using a B4-level scanner, all programs made for B1 through B3 levels should run with no problem. All scanners feature the control codes from lower level machines.

However, some scanner settings are unique to particular scanner models, so you must take these into account when writing scanner programs.

## Parameters

Some commands require additional parameters. Commands that require parameters do not take effect until the parameters are sent, so always make sure you send the correct parameters. Sending an incorrect parameter may cause a scanner error.

---

## Computers and Handshaking

Scanners are connected to their host computers by some kind of interface. Since a scanner sends data to the computer, the interface must carry data not only from the computer to the scanner, but also from the scanner to the computer. For this reason, the interface must be capable of bi-directional communication.

A method of interaction between the computer and scanners is necessary to prevent the computer from sending data at the same time the scanner is sending data. This interaction method is the basis for governing scanner operation.

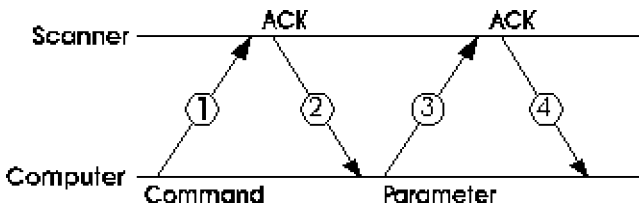

EPSON scanner and computer interaction is controlled by a method called handshaking. After the computer sends data to the scanner, it must wait for the proper reply from the scanner before sending more data. Also, when the scanner sends data to the computer, it must wait for the correct response from the computer before sending additional data. Handshaking dictates the method of sending data and how the data is acknowledged by both the computer and scanner.

---

## **Image Data**

The manner in which an image is converted into data and the way the data is sent to the computer is predetermined. The following sections describe this process.

### **Image data format**

The smallest element of image data is called a pixel (short for picture element). A pixel is an individual dot; combining these dots, or pixels, forms an image.

If you represent each pixel by one bit of data, you can determine whether that pixel is light or dark (1 or 0). This is called bi-level conversion, and produces bilevel data.

However, most images contain a nearly infinite number of color shades. By increasing the number of data bits per pixel, you can increase the possible number of pixel shades you can represent. As you can see from the following illustration, 1 bit per pixel allows you to show only two shades; 2 bits per pixel allows you to represent up to 4 shades.

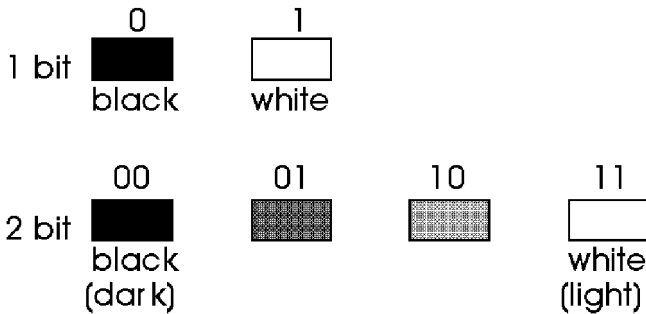

The image data format is what determines the amount of data necessary for each pixel. The amount of data determines how many shades you can express. Normally, you can select from 1 to 8 bits per pixel. For monochrome scanning, this data determines the shade of gray. For color scanning, you can differentiate the same number of shades for each of three colors (green, red, and blue).

As you increase the amount of data, you dramatically increase the number of minute differences in color you can represent.

<b>Bits per pixel</b>	<b>Monochrome shades</b>	<b>Colors</b>
1 bit/color/pixel	2	8
2 bits/color/pixel	4	64
3 bits/color/pixel	8	512
4 bits/color/pixel	16	4,096
5 bits/color/pixel	32	32,768
6 bits/color/pixel	64	262,144
7 bits/color/pixel	128	2,097,152
8 bits/color/pixel	256	16,777,216



# Line data transfer

The scanner reads one horizontal line of data (main scan) and sends it to the computer. After the computer confirms it has received the data, the scanner sends the next line of data. The scanner repeats these steps until data for the entire image is sent to the computer. This method is called line data transfer.

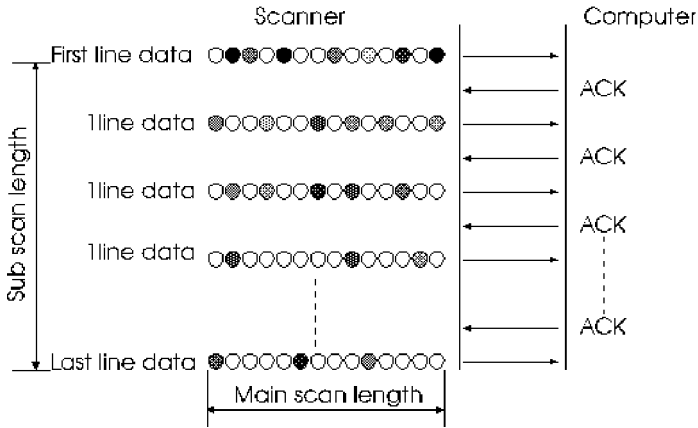

## Block data transfer

Line data transfer sends the data to the computer line by line. However, block data transfer sends multiple lines of data to the computer all at once. You can use commands to specify the number of lines sent at one time; in this way you can select the most efficient block size to send your data.

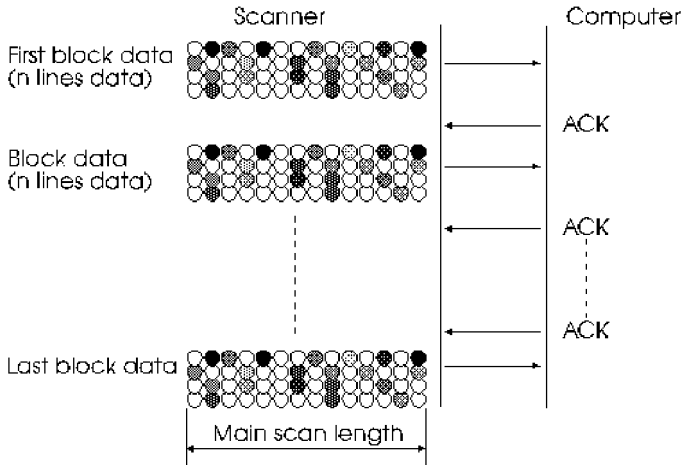

---

## **Functions**

EPSON scanners feature a number of various functions. A brief overview of these functions is provided below. For more detailed explanations, see the following chapter on using these functions, as well as the command reference section.

### **Image definition**

#### **Brightness**

This function allows you to set the brightness at which images are scanned. The following illustration shows the difference this setting can make in the final scanned image. Setting the brightness to a brighter setting results in a bright image in which some thinner lines may be washed out. On the other hand, setting brightness to a darker setting results in a blacker image in which some intricate details may turn out completely black.



# Gamma correction

Gamma correction is a function that adjusts the light intensity so it matches the output device.

Although an image may display clearly on your CRT display, your printer may not produce it the same way. Since image reproduction depends on the output device (CRT, printer, etc.), gamma correction adjusts the light intensity so the image is faithfully reproduced on the output device you are using. The term gamma refers to the ratio between the input and output light intensity.



Display A



Display B



Printer A



Printer B



Printer C

## Halftoning

Halftoning adjusts the shade and color of each pixel according to the shade and color of the surrounding pixels. Setting halftoning to large results in a sharper contrast between dots. Setting halftoning to small results in reduced contrast.

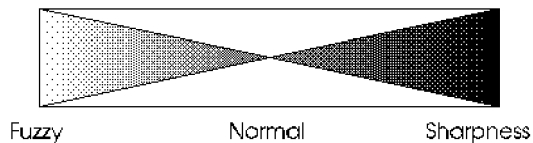

## **Data form definition**

### **Data format**

The data format function determines how many bits are used to represent one pixel. Increasing the bits increases the number of shades and intensity that can be expressed. However, the data required to represent an image is also increased. For example, to scan an A4 size image using 8 bits per pixel at 300 dots per inch (dpi) in color would require 26.4 MB of data.

Also, if your printer or CRT is not capable of expressing these differences in color and shade, there is no reason to produce such precise (and sizable data).

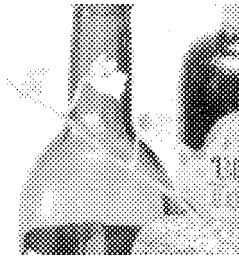

8 bit



2 bit



1 bit

## Resolution

The resolution determines how detailed a scan is. The resolution is normally defined as the number of dots scanned per inch. The units of resolution are dots per inch. You can also think of it as the density of pixels in the image.

The greater the resolution, the greater the image detail you can scan. However, the more detail you have, the greater the amount of data a scan produces. For example, doubling the resolution in both the horizontal and vertical directions results in four times the amount of data.

Each output device also has its own specific resolution. If you scan an image at the same resolution as your output device, the final image will be the same size as the original. Likewise, if you scan an image at double the resolution of your output device, the final image will be twice the size of the original.

**Note:**

*Some software may adjust images that include resolution information so they appear as their actual size.*

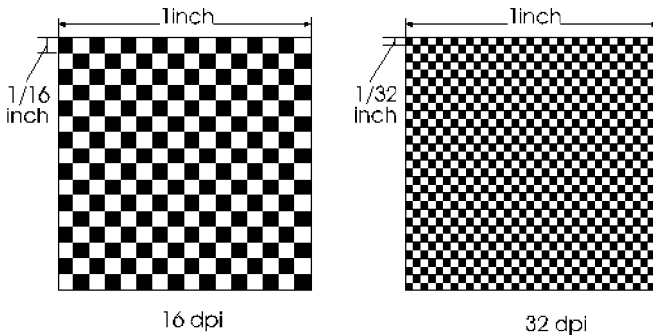

## **Zoom**

The zoom function causes an image scanned at the same resolution as the output device to be output at a greater size than the original. The zoom function can be set independently from the resolution setting.

Since the zoom function enlarges or shrinks the image of the original document, the data amount expands or shrinks in response to the zoom setting.

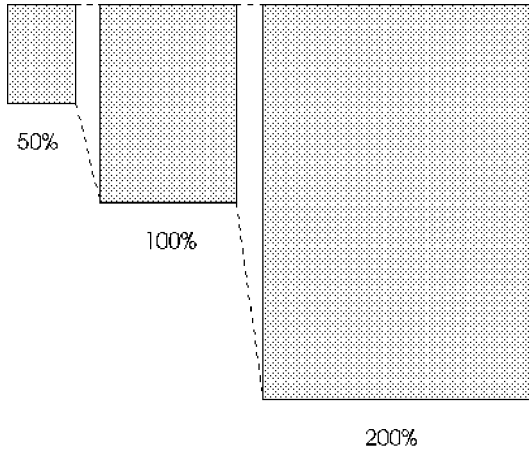



## Scanning area

The maximum scannable area for each scanner is determined by the physical dimensions of the document table. You can also use commands to tell the scanner to scan only a certain portion of your document.

You set the scanning area in units of pixels. First set the point to begin scanning, and then set the number of pixels beyond that point you wish to scan.

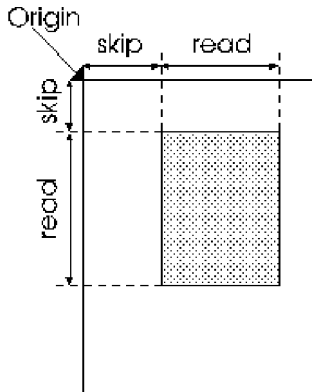

Since you set these values as the number of pixels, using the zoom function or changing the resolution affects the physical size of the scanning area.

## ***Color setting***

Setting the color determines the method used for scanning.

If you select monochrome scanning, you can specify either red (R), green (G), or blue (B) as the dropout color. The scanner then ignores the specified dropout color when scanning a document. For example, if you want to read a document that has been marked with red pen, you can select the dropout color to be red; the scanner then ignores the red markings and scans only the original document.

If you select color scanning, you can choose page scanning, line scanning, or byte scanning. Page scanning scans the entire page three times; once for each color. Line scanning scans all three colors line by line. Byte scanning scans byte by byte.

## ***Image processing***

### ***Halftoning***

For documents with many shade gradations (like a photograph) in full-color mode (24-bit data), you can faithfully reproduce the image on a full-color output device. Some output devices, such as 8-color PC monitors or 8-color printers, cannot faithfully portray a full-color image; however, a method does exist for approximating multiple shades on these types of output devices.

For example, by adjusting black and white pixels slightly, you can approximate various shades of gray between black and white. This type of data processing is called halftone processing, and several versions are available on EPSON scanners. Two typical forms of halftone processing are dither processing and density pattern processing. Dither processing is the normal type of data processing found on scanners. EPSON scanners also represent halftones using dither processing.

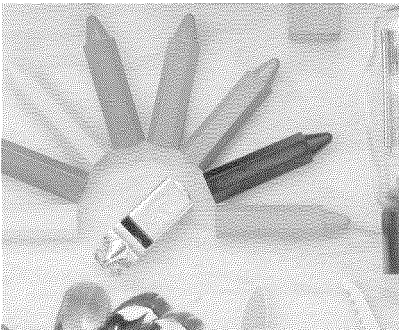

Halftone mode A

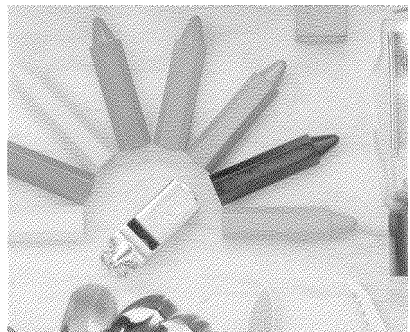

Halftone mode B

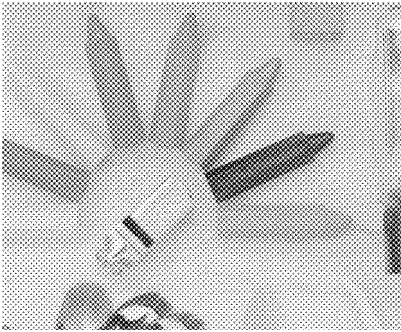

Halftone mode C



None

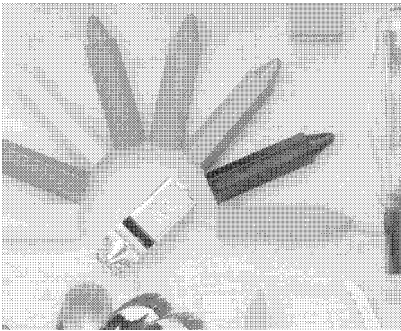

Dither mode A

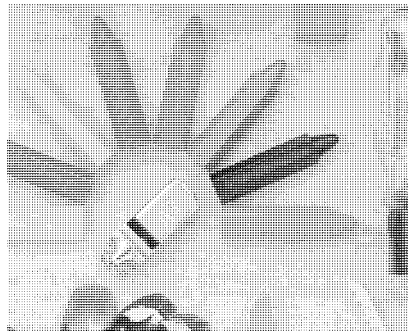

Dither mode B

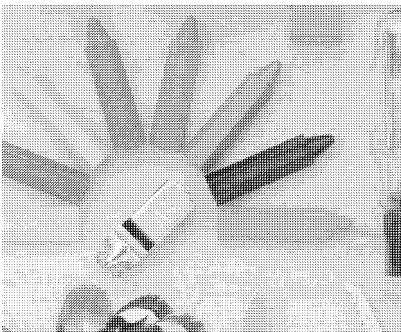

Dither mode C

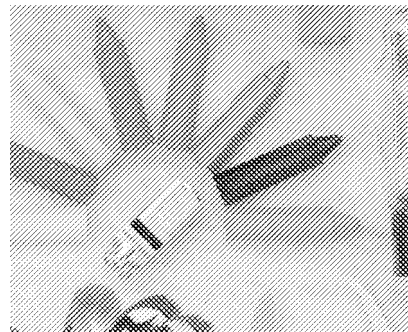

Dither mode D

## ***Color correction***

Colors expressed on different types of color output devices vary slightly depending on each device's characteristics. The color correction feature allows you to adjust colors on output devices to more closely approximate your original document.

---

## ***Using Scanner Features***

The scanner functions you use will vary, depending both on the type of document you are scanning and the output device you plan to use. This section describes which features are available for which types of documents, as well as which features are available with which types of output devices.

### ***Scanning multiple shade documents for output on devices capable of expressing multiple shades.***

When you scan multiple shade documents (such as photographs or pictures) and output them to devices capable of expressing multiple shades (such as full-color computers or color film recorders), use the following feature settings for best results.

<b>Data format</b>	3 to 8 bits/pixel/color
<b>Image correction</b>	Method appropriate to output device
<b>Data processing</b>	No

## ***Scanning multiple shade documents for bi-level output devices capable of black and white only***

When you scan multiple shade documents and output them to devices capable of expressing only black and white, use the following feature settings for best results.

<b>Data format</b>	1 bit/pixel/color
<b>Image correction</b>	Method appropriate to output device
<b>Data processing</b>	Yes

## ***Scanning documents without multiple shades***

When you scan line drawings, characters, logos, diagrams, etc., turn all data and image processing off and scan the document. This allows you to achieve the maximum contrast possible.

<b>Data format</b>	1 bit/pixel/color
<b>Image correction</b>	Standard settings
<b>Data processing</b>	No

## ***Scanning documents to obtain unprocessed data***

If you want to perform all data processing using your application software, with no processing by the scanner, use the following feature settings for best results.

<b>Color setting</b>	Page scanning
<b>Data format</b>	8 bits/pixel/color
<b>Image correction</b>	Standard settings
<b>Brightness</b>	One step darker than standard



---

## **Execution Commands**

Execution commands tell the scanner to send back data to the computer.

Use execution commands to begin image data transfer from the scanner to the computer, to obtain the scanner ID and status, and to obtain information on the current scanner settings.

### **1. Start scanning (ESC G)**

Upon receiving this command, the scanner begins scanning and sending image data to the computer. The scanner sends image data in data blocks that consist of one or more lines.

After the computer receives a complete data block, it should send an ACK code to the scanner to confirm receipt.

When the scanner receives the ACK code, it begins sending the next data block.

This process is repeated over and over to continue sending data. However, the computer should not send an ACK code after the final data block.

To determine the final data block, refer to the status information block at the beginning of each data block. See page 2-28 for details on the status information block.

### ***ESC G and other commands***

The ESC G command begins scanning based on the current scanner settings. Make sure you use the other commands to make your desired settings before sending the ESC G command.



## **2. Request ID (ESC I)**

When the scanner receives this command, it relays the scanner ID information to the computer in the following order.

Scanner command level

Available resolution values

Maximum scannable area

(at the highest resolution, with 100% zoom)

If you are creating a program for use with different scanner models, you can use this command to determine the features and settings available on the connected scanner model.

The ID information is transferred as a data block from the scanner to the computer. See Appendix B for details on the ID information for each scanner model.

## **3. Request Status (ESC F)**

When the scanner receives the ESC F command, it sends a data block to the computer that includes the status information. See page 2-28 for details on status information. The length of the information block within the data block is four bytes. The contents of these four bytes are as follows:

<b>Header (STX)</b>	1 byte
<b>Status</b>	1 byte
<b>Byte counter</b>	2 bytes

## **4. Extended Status Request (ESC f)**

Upon receiving this command, the scanner sends a data block to the computer that includes the status of the scanner and any options installed.

The data block is composed of the normal information block combined with 33 bytes of extended status data.

## 5. Request condition (ESC S)

This command causes the scanner to send a data block to the computer that contains the current values of the settings for all the scanner's features.

The features available are different for each scanner model. Following is a sample of a B4-level data block sent when the scanner receives this command.

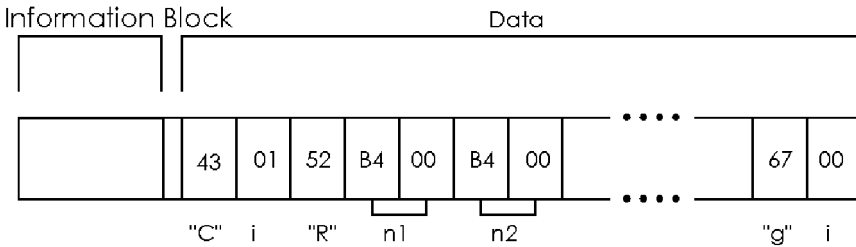

The ESC code and command code are ASCII character data. The 1 or 2 bytes of binary data that follow are that command's setting (parameter) value. Two-byte data is listed with the lower byte first and the upper byte last.

---

## **Data Form Commands**

Data form commands regulate the amount of image data sent to the computer (as determined by the setting for scanning color, resolution, tone, and zoom).

### **1. Set Color Mode (ESC C)**

This command sets either color or monochrome scanning.

If you select color scanning, you must specify page scanning, line scanning, or byte scanning. Page scanning scans the entire page three times; once for each color. Line scanning scans for each color on a line-by-line basis. Byte scanning scans on a byte-by-byte basis.

If you select monochrome scanning, you can specify red, green, or blue to be a dropout color.

#### *ESC C and other commands*

Selecting line scanning or byte scanning enables the use of the Color Correction Command (ESC M).

### **2. Set Data Format (ESC D)**

This command sets the number of bits available for representing each color (green, red, and blue during color scanning). The number of bits determines the number of shades that can be represented for each color; the more bits, the more colors available. However, increasing the number of shades available also increases the overall data required to represent an image.

For example, if you specify 8 bits per pixel for each color, the scanner produces 8 bits of data per pixel per color. This requires eight times the data necessary to represent 1 bit/pixel/color. As the number of bits per color changes, the data format for each byte of data changes as shown below:

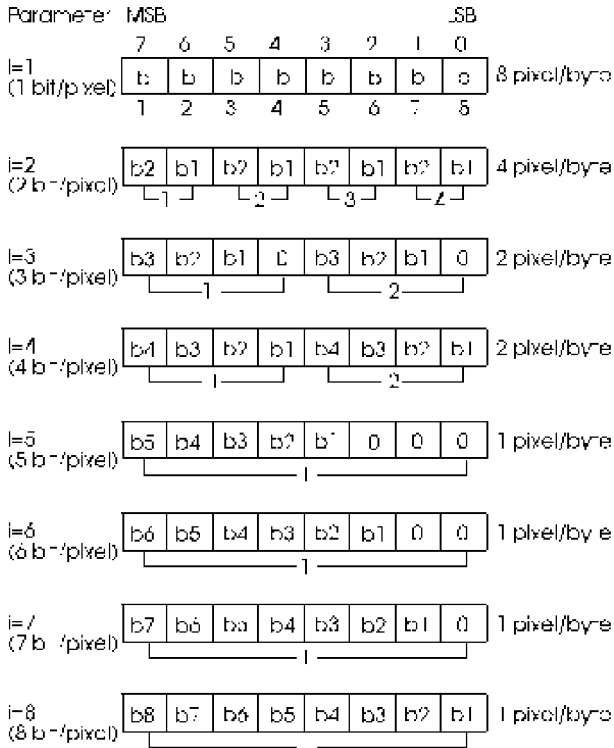

### ESC D and other commands

Halftone processing with the ESC B command is only available when the number of bits/color/pixel is set to 1 or 2.

Setting the data format to 2 bits/color/pixel disables halftoning modes B and C on the GT-1000, GT-4000, GT-6000, GT-6500, ES-300C, and ES-600C. (You can select halftoning modes B and C, but mode A processing takes place instead.) Selecting a data format of 3 bits/color/pixel disables all halftoning modes on all scanner models.

### **3. Set Resolution (ESC R)**

You can set different values for the resolution for the main scan (horizontal direction) and the sub scan (vertical direction). You can find the resolutions available by reading the scanner's user's manual or, from within a program, sending the ID Request command.

#### *ESC R and other commands*

Multiple resolutions are available on all scanners. You can check the resolutions available on the currently connected scanner by checking the data block returned by the scanner when you send the ID Request command. For B5- and A5-level scanners, you can select a resolution from 50 dpi to the maximum available resolution of the scanner in 1-dpi increments. Trying to select a resolution that is not available results in a command error.

This command determines the number of pixels that can be scanned within the scanning area, based on the current zoom setting. Because of this, you should always set the zoom and resolution before setting the scanning area.

Even if your desired resolution is not available on the current scanner, you can still adjust the zoom and resolution settings to approximate your desired resolution. First set the resolution to the value closest to your desired setting; then adjust the zoom until the resolution value approximates your desired setting.

### **4. Set zoom (ESC H)**

You can set the zoom (image enlargement/reduction) for the main scan and sub scan independently, between the values of 50% to 200%.

After the scanning resolution is set, this command enlarges or reduces the number of dots scanned, independent of the resolution. This results in the scanned image being enlarged or reduced.

### *Set zoom and other commands.*

The combination of this command and the ESC R (Set resolution) command determine the maximum number of dots you can scan. You can calculate the number of dots by multiplying the zoom percent by the original dot setting.

## **5. Set scanning area (ESC A)**

This command selects the area to be scanned.

The main scan and sub scan are set in units of dots (in the current resolution) measured from the origin. First you set the “skip distance” from the origin to the beginning of the main scan and sub scan. Then you set the length of the main and sub scan as measured from the point defined by the skip distance.

You must always set the main scan length in 8-dot units. However, the skip distances and the sub scan length can be set in 1-dot units.

### *ESC A and other commands*

Setting the resolution and zoom value determines the maximum scannable area. You cannot set values that would exceed this maximum scannable area.

## **6. Set data order (ESC K)**

This command selects the order in which image data is scanned. You can set the direction from left to right or from right to left.

---

## Image Setting Commands

Image setting commands are commands that tell the scanner what kinds of image processing to perform on the image data. Brightness settings and gamma correction (adjusting for input and output brightness) settings are examples.

### 1. Set brightness (ESC L)

This command sets the scanning brightness. If the standard brightness setting results in images that are too dark or light, use this command to adjust the brightness. You can select from among seven brightness levels; settings in between these seven levels are not possible.

The Set brightness (ESC L) command is ineffective when a gamma table defined with the ESC z command is selected by the ESC Z (Set gamma correction) command.

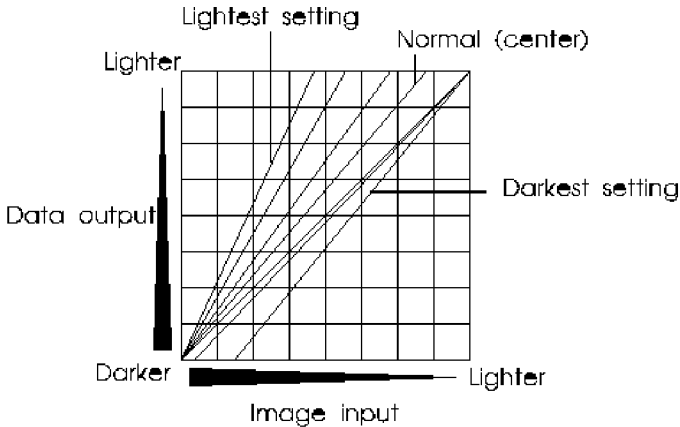

## 2. Set gamma correction (ESC Z)

This command adjusts the scanned data according to the type of output device you plan to use.

The gamma correction setting is independent of any other scanner settings.

On B4 and higher-level scanners, you can use the ESC z command to define gamma correction tables to match the unique needs of specific types of documents and output devices.

Gamma correction processes data for various types of output devices as explained below:

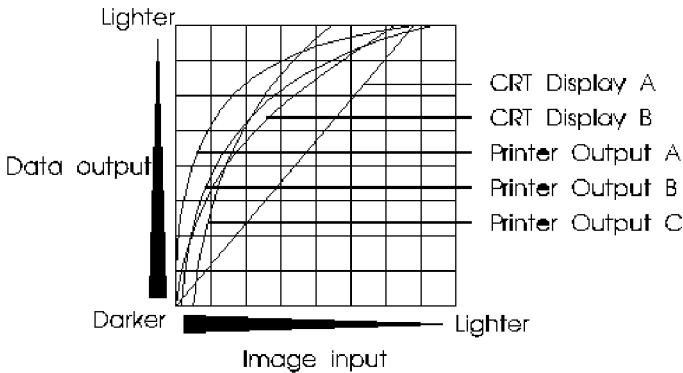

### **CRT Display A**

This setting takes the scanned data and converts it directly to image data. This is suitable for displays that are incapable of displaying different tones of gray or color; for example, displays that can display only 8 or 16 colors. This is also recommended for line or character data that is scanned as bi-level data (1 bit/pixel/color).



## ***CRT Display B***

This setting is suitable for 256-color displays and other displays that are capable of showing multiple color levels. On these types of displays, scanned data appears dark and grainy. CRT Display B gamma correction processes the image data to appear more continuous, improving its display appearance. On identical computers, CRT Display B images appear brighter than CRT Display A images.

## ***Printer Output A***

This is the best choice for output on high-resolution printers (24-dot matrix and laser printers). This type of correction processes image data to appear more as individual dots, lightening the image. This type of processed image may appear light or washed out when shown on a computer display.

## ***Printer Output B***

Use this type of correction when printing out on low-resolution printers (9-dot matrix). This type of output device produces images that appear grainy; Printer Output B correction adjusts the data to appear more continuous. The resulting image may appear light or washed out on a computer screen. Also, Printer Output A images appear lighter than Printer Output B images when output on the same device.

## ***Printer Output C***

Use this type of processing when images and data are combined. If you use this type of correction, black characters in an image appear sharper, while illustrations are not affected.

### 3. Download gamma table (ESC z)

Using this command, you can select the table used for gamma correction. You can specify the type of output adjustment produced for each of the 256 available color tones.

For example, to achieve the following type of image correction, you can set the values determined by the equation below.

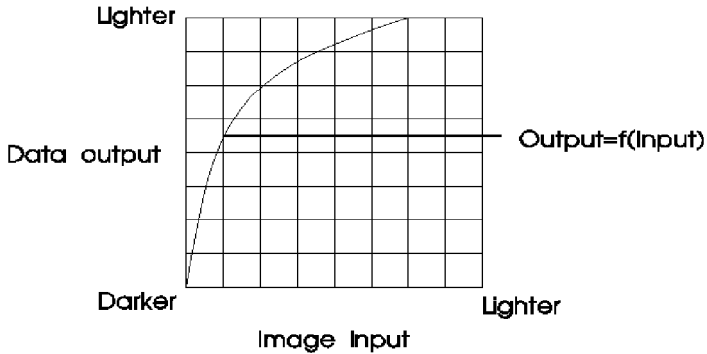

### 4. Set Sharpness (ESC Q)

This command is used to emphasize or de-emphasize the edges in your images. Five settings are available. Emphasizing the edges of an image makes it appear sharper. De-emphasizing the edges make it appear softer. It is difficult to classify which images appear better with which setting; you must match this setting to your particular document and output device.

---

## **Image Processing Commands**

Image processing commands are used to modify scanned data before sending it to the computer. Two commands are available: halftone processing and color correction.

### **1. Set halftoning mode (ESC B)**

This command enables or disables halftone processing for bi-level data and quad-level data. The type of processing performed is outlined below. However, the type of processing available differs by scanner model. See Appendix B for details.

This command also enables or disables Text Enhancement Technology. This function is only available for B5 or A5 command level scanners or higher.

- No data processing

Unprocessed data is sent directly to the computer. Use this setting when scanning characters or line art that needs no processing.

- Halftoning mode A

Produces hard tones using the Error Diffusion method, producing images with higher contrast. This is appropriate for most images.

- Halftoning mode B

Produces soft tones using the Error Diffusion method. This method produces a softer image than halftoning mode A.

- Halftoning mode C

Produces an image using a screen, again using the Error Diffusion method.

- Dither mode A

Processes data using a 4×4 Bayer pattern

❑ Dither mode B

Processes data using a 4×4 spiral pattern

❑ Dither mode C

Processes data using a 4×4 screen pattern

❑ Dither mode D

Processes data using a 8×4 screen pattern

❑ User-defined modes A and B

Processes data using the pattern defined with the ESC b command

### ***Built-in dither patterns***

	Dither mode A 4x4 Bayer	Dither mode B 4x4 Spiral	Dither mode C 4x4 Net screen																																																
Dither pattern	<table border="1"><tr><td>15</td><td>7</td><td>13</td><td>5</td></tr><tr><td>3</td><td>11</td><td>1</td><td>9</td></tr><tr><td>12</td><td>4</td><td>14</td><td>6</td></tr><tr><td>0</td><td>11</td><td>2</td><td>10</td></tr></table>	15	7	13	5	3	11	1	9	12	4	14	6	0	11	2	10	<table border="1"><tr><td>2</td><td>9</td><td>8</td><td>1</td></tr><tr><td>10</td><td>15</td><td>14</td><td>7</td></tr><tr><td>11</td><td>12</td><td>13</td><td>6</td></tr><tr><td>3</td><td>4</td><td>5</td><td>0</td></tr></table>	2	9	8	1	10	15	14	7	11	12	13	6	3	4	5	0	<table border="1"><tr><td>1</td><td>2</td><td>9</td><td>6</td></tr><tr><td>3</td><td>15</td><td>14</td><td>8</td></tr><tr><td>10</td><td>12</td><td>13</td><td>5</td></tr><tr><td>7</td><td>11</td><td>4</td><td>0</td></tr></table>	1	2	9	6	3	15	14	8	10	12	13	5	7	11	4	0
15	7	13	5																																																
3	11	1	9																																																
12	4	14	6																																																
0	11	2	10																																																
2	9	8	1																																																
10	15	14	7																																																
11	12	13	6																																																
3	4	5	0																																																
1	2	9	6																																																
3	15	14	8																																																
10	12	13	5																																																
7	11	4	0																																																
Threshold value	<table border="1"><tr><td>248</td><td>120</td><td>216</td><td>88</td></tr><tr><td>56</td><td>184</td><td>24</td><td>152</td></tr><tr><td>200</td><td>72</td><td>232</td><td>104</td></tr><tr><td>8</td><td>136</td><td>40</td><td>168</td></tr></table>	248	120	216	88	56	184	24	152	200	72	232	104	8	136	40	168	<table border="1"><tr><td>40</td><td>152</td><td>136</td><td>24</td></tr><tr><td>168</td><td>248</td><td>232</td><td>120</td></tr><tr><td>184</td><td>200</td><td>216</td><td>104</td></tr><tr><td>56</td><td>72</td><td>88</td><td>8</td></tr></table>	40	152	136	24	168	248	232	120	184	200	216	104	56	72	88	8	<table border="1"><tr><td>24</td><td>40</td><td>152</td><td>104</td></tr><tr><td>56</td><td>248</td><td>232</td><td>136</td></tr><tr><td>168</td><td>200</td><td>216</td><td>88</td></tr><tr><td>120</td><td>184</td><td>72</td><td>8</td></tr></table>	24	40	152	104	56	248	232	136	168	200	216	88	120	184	72	8
248	120	216	88																																																
56	184	24	152																																																
200	72	232	104																																																
8	136	40	168																																																
40	152	136	24																																																
168	248	232	120																																																
184	200	216	104																																																
56	72	88	8																																																
24	40	152	104																																																
56	248	232	136																																																
168	200	216	88																																																
120	184	72	8																																																

Dither mode D  
8x4 Net screen

29	23	6	0	8	12	20	28
22	5	1	17	16	11	13	21
4	2	18	26	25	15	10	9
3	19	27	31	30	24	14	7
8	12	20	28	29	23	6	0
16	11	13	21	22	5	1	17
25	15	10	9	4	2	18	26
30	24	14	7	3	19	27	31

Dither pattern

236	188	52	4	68	100	164	228
180	44	12	140	132	92	108	172
36	20	148	212	204	124	84	76
28	156	220	252	244	196	116	60
68	100	164	228	236	188	52	4
132	92	108	172	180	44	12	140
204	124	84	76	36	20	148	212
244	196	116	60	28	156	220	252

Threshold value

### *ESC B and other commands*

The scanner ignores the image processing you select with the ESC B command if you have already selected 3 bits/color/pixel or higher with the ESC D command.

## **2. Download dither pattern (ESC b)**

This command defines the dither pattern that is selected when you use ESC B to select user-defined dither patterns A and B. You can select square patterns with sizes of 4x4, 8x8, and 16x16. You define the dither pattern by assigning a threshold data value to each pattern member. Since image data has a value from 0 to 256, you can set the threshold value from 0 to 256.

The threshold values you define with this command remain in effect until you turn off the scanner or redefine new values. The ESC @ (Initialize the scanner) command does not clear these values.

To determine the data for a typical spiral dither pattern like the one shown in figure a, multiply the threshold value by 16 and add 8; the results are the values shown in figure b. The data is then sent in the order shown in figure c.

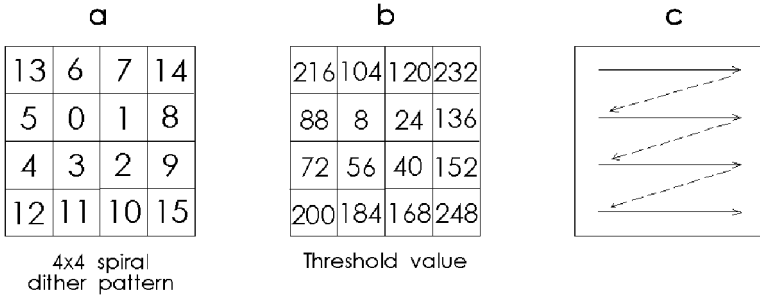

### 3. Set color correction (ESC M)

Color correction adjusts the colors to match those available on your output device.

The color produced by different output devices varies depending on the method used to express color. You can use this command to correct colors to match various output devices.

The following output devices can be selected with this command.

- Dot-matrix impact printers

Use for color impact printing.

- Thermal printers

Use for color thermal printing.

- Ink-jet printers

Use for color ink-jet printing.

- CRT displays

Use for color CRT displays

- User defined setting

Use for your customized output.

- No color correction

### *ESC M and other commands*

The ESC M command is effective only after you select color line scanning or byte scanning with the ESC C command.

## **4. Download color correction (ESC m)**

Using this command, you can set the data for color correction. The scanner converts the color data in accordance with the data specified by this command.

---

## **Auxiliary Commands**

Auxiliary commands are provided for physical operation of the scanner. These commands include the reset command and option operation commands.

### **1. Initialize the scanner (ESC @)**

This command returns all scanner settings to their original values (the values when the scanner is first turned on). The carriage returns to the home position. However, the definitions created with the ESC b and ESC z commands are not erased.

### **2. Set the scanning mode (ESC g)**

You can select from two modes with this command: high-speed mode and normal mode. The scanner is always in normal mode unless you change it with this command. If you are scanning at 8 bits/pixel (in monochrome) or 8 bits/color/pixel (in color) you must select normal mode.

In high-speed mode, the scanner moves its sensor faster. This is useful if a high degree of scanning precision is not required, or if you are scanning bi-level data such as characters or line drawings.



### **3. Set the line counter (ESC d)**

Sending this command causes the scanner to send data in block format. If you don't send this command at the beginning of each job, the scanner defaults to line mode and sends data after each line is scanned.

You can set the parameter in this command from 1 to 255 lines. This tells the scanner how many lines to send to the computer at a time. In other words, setting the parameter to 10 results in the printer sending scanned data in blocks 10-lines long. During line mode, the scanner confirms that the computer receives each line of data after it is sent. By sending data in blocks of multiple lines, you can save the time required for line-by-line confirmation.

Setting the line counter with this command does not necessarily mean the final data block will include that exact number of lines. Make sure your program always checks the line counter value included in each data block when receiving data. For example, if the value  $X$  is the number of total lines you are scanning, the number of lines in the final data block would be  $\text{MOD}[X/i]$ . The operator MOD indicates the remainder of the division operation.

#### *ESC d and other commands*

If you select color line scanning with the ESC C command, you must select a parameter for the ESC d command that is a multiple of 3.

## **4. Control option (ESC e)**

This command is effective only when an option has been installed on the scanner. If you send these commands when no option is installed, the scanner returns a NAK signal and a command error results.

You can check if an option is installed by either using the ESC f command or by checking the option flag in the status byte.

When using the optional Automatic Document Feeder, you cannot select color page scanning; you should always use the ESC C command to select color line scanning, byte scanning, or monochrome scanning.

If you send this command when using the optional Transparency Unit or Automatic Document Feeder, the scannable area changes. Check the extended status information to determine the new scannable area.

## **5. Eject (FF)**

If you send this command when the Automatic Document Feeder is installed, the scanner returns an ACK code and ejects the document when scanning is completed.

---

## **Control Codes**

These are commands that control data transfer.

### **1. Header (STX)**

Send this code to indicate the beginning of a data block.

## **2. Abort scanning (CAN)**

Usually you send an ESC G command to start scanning and, after the scanner sends a data block, the computer responds with an ACK code to confirm the data was received. If the computer sends a CAN code instead of the ACK code, the scanner cancels scanning and stops sending data.

The scanner recognizes the CAN code only after it has sent a data block and is waiting to receive the ACK code from the computer. If the scanner receives the CAN code when it is waiting to receive a command, a command error results.

After the scanner cancels scanning, the carriage returns to the home position. Other scanner settings are not affected by canceling scanning. Also, scanning does not resume at the position where it was canceled.

## **3. Normal response (ACK)**

When the scanner receives correct commands or parameters, it sends this code to the computer as a kind of confirmation.

When sending image data, the computer should send an ACK code to the scanner after it receives each data block. When scanning in color, the computer should send an ACK code after each data block for each color.

## **4. Negative response (NAK)**

When the scanner receives an incorrect command or parameter, it sends a NAK code. When the scanner sends this code, a command error also results.

If the scanner returns a NAK code, the previously sent command is not performed. If you were trying to change a scanner setting, the previous setting remains in effect.

---

## **Command Order**

By using the Request ID (ESC I) command, you can determine the scanner model. This allows you to create software that sends only the commands featured on that particular model. Always check the scanner ID before making settings with software commands.

The ID information consists of the following:

- The scanner function level
- The available scanner resolutions
- The maximum scannable area

The maximum resolution and maximum scannable area values are used to determine the available parameters in the Set scanning area (ESC A) command when zoom and resolution are changed.

### ***ID information***

#### 1. Scanner function level

The scanner level indicates which commands are supported on the connected scanner, allowing you to make full use of the scanner's features. You also can determine which commands are not available, so you can avoid causing command errors.

#### 2. Available resolutions

All scanning resolutions available on the connected scanner are listed in the ID information. All resolutions are available for both the main scan and sub scan; the main scan and sub scan values can be set independently from each other. The last resolution value is the highest resolution available on the scanner.

### 3. Maximum scannable area

This value is expressed in units of dots (main scan × sub scan), based on the maximum scannable area available when the scanner is set to the highest available resolution and zoom is set to 100%.

## **Control flow**

Using the ID information, you should send commands to the scanner in the following order.

1. Obtain the scanner's ID information by sending the ESC I command.
2. After checking the scanner function level, send commands available at that level to make the various scanner settings.
3. Refer to the resolution and maximum scannable area information in the ID information and set the resolution, zoom, and scanning area.
4. Start scanning.

To scan again, repeat steps 2 through 4 above.

## ***Recommended command order***

Send commands in the following order to control the scanner properly. Make sure to send the ESC R, ESC H, ESC A, and ESC G commands in the following order.

ESC I Request ID  
ESC e Control option  
ESC C Set color  
ESC D Set data format  
ESC B Set halftoning mode  
ESC L Set brightness  
ESC Z Set gamma correction  
ESC M Set color correction  
ESC Q Set sharpness  
ESC g Set the scanning mode  
ESC K Set data order  
ESC R Set resolution  
ESC H Set zoom  
ESC A Set scanning area  
ESC d Set line counter  
ESC G Start scanning

## ***Using commands when options are installed***

With scanners that are capable of using options, your programs should always check the flag in the status byte to determine if options are installed. Then use the following steps to operate the scanner.

1. Use the ESC I (Request ID) command to obtain the scanner's ID information. This information includes the scanner's function level, the scan resolutions available, and the maximum scannable area.
2. Check bit 4 in the ID information status byte. If the bit is not set to 1, no option is installed and option use should be discontinued.
3. Send the ESC f (Request extended status) command to determine the option's maximum scannable area.
4. Send the ESC e (Control option) command and enable the option.

5. Following the order on the previous page, send the command to set the scanning area and send any other commands necessary to prepare for scanning. For details on these commands, see Chapter 3.
6. Send the ESC f command. Check if the option is enabled and make sure no error has occurred. In an error occurs, perform the proper error recovery procedures.
7. Send the ESC G (Start scanning) command.
8. Receive the image data. If an error occurs during data reception, the status byte's error flag and area end flag are set to 1, and the byte counter is set to 0; scanning then ends. After clearing the cause of the error, send the ESC @ (Initialize the scanner) command to reset the scanner and return to step 4.
9. After image scanning is complete, send the FF (Eject document) command (only if you are using the ADF).
10. To repeat scanning, return to step 6.
11. If you don't plan to use an installed option, always send the ESC e command to disable the option before you begin scanning.

---

## Data Block Transfer Order

The computer sends commands and parameters to the scanner in 8-bit code format. The scanner sends data to the computer in groups of 8-bit codes called “blocks.”

### Data block structure

Data blocks can take two forms: line data structure and block data structure.

**Note:**

*The scanner must support the ESC d (Set line counter) command and be function level B4 or higher to transfer data using the block data structure.*

A data block consists of two parts: the first part contains a header and status block; the second part is the scanned data extended.

### Line data structure

Line data consists of a 4-byte information block followed by either an ID information data, an extended status data, or one line of the main scan image data.

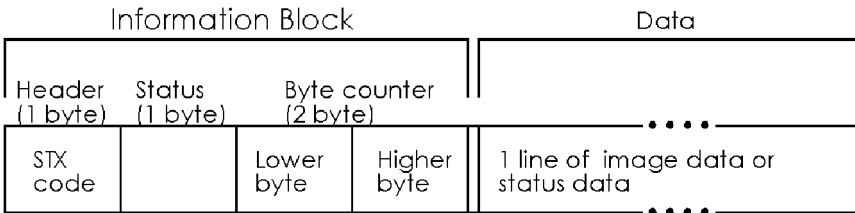

The information block size is fixed at four bytes. The amount of data following differs depending on the data type. The byte counter in the information block specifies how much data is contained in the block.



## Block data structure

Block data consists of a 6-byte information block followed by  $n$  lines of image data ( $n$  is the value of the line counter in the information block).

You specify block data transfer with the ESC d (set line counter) command. By sending multiple lines of data at once, you can shorten the total data transfer time.

The information block size is fixed at 6 bytes. You can use the byte counter and line counter in the information block to determine the amount of data (number of bytes).

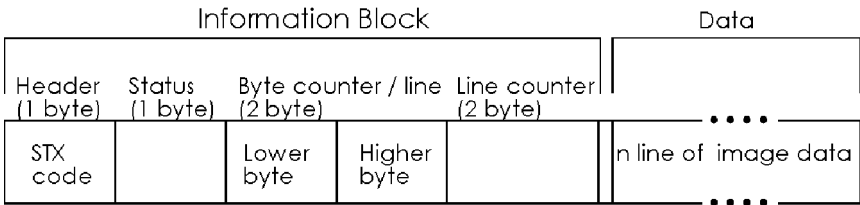

## Information block

An information block is included in all data blocks; and provides information on the beginning of the data block, the current state of the scanner, and the length of the data that follows.

### Header

This byte is always set to the STX code (02H), and indicates the beginning of the data block.

## Status byte

This byte indicates the color of the image data or the state of the scanner. Each bit in the Status byte has a different meaning, as shown in the following diagram. Currently, bits 0, 1, and 6 are reserved (not used).

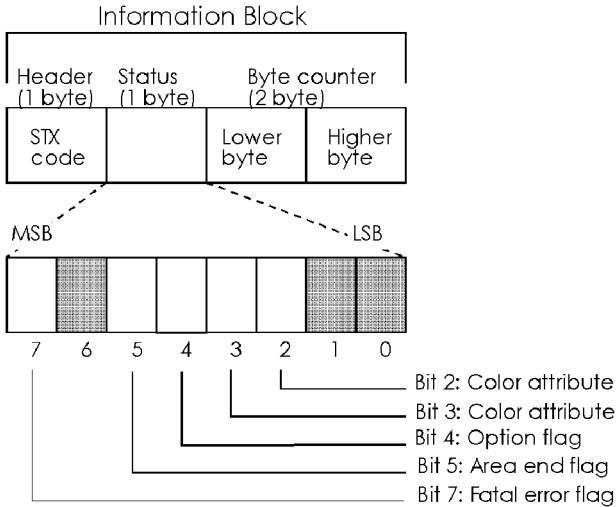

### Error flag (bit 7)

This flag is set to “1” when an error other than a command error occurs. In this case, no data follows, so the byte counter is set to 0 (00H, 00H).

If a system error occurs, the scanner accepts only the ESC F and ESC f commands. These two commands are used to determine if a system error has occurred.

### Area end flag (bit 5)

This flag is set to “1” when the data block is the final block of scanned data in the scanning area. Do not send an ACK code to the scanner after receiving the final data block (when this flag is set to 1).

### Option flag (bit 4)

This flag is set to “1” when an option is installed.

### Scanning color (bits 2 and 3)

These bits indicate the scanning color. When monochrome is selected, these bits indicate the dropout color (if a dropout color is selected).

### *Byte counter*

The byte counter indicates the number of data bytes contained in each data line. The counter consists of two bytes (an upper and lower byte); the value of the counter is determined according to the following formula:

$$(\text{number of data bytes}) = (\text{lower byte}) + (256 \times (\text{upper byte}))$$

Make sure that your program checks the byte counter in each data block and receives all data sent by the scanner. If the computer does not accept all data, the scanner goes into a waiting state.

### *Line counter*

When in block data transfer mode, this counter indicates the number of lines of image data in the block. When in color line scanning mode, data is organized in successive lines of green, red, and blue data (in that order). Each color is counted as a separate line, so the line counter must be a multiple of three. For example,  $n$  lines of color data result in a line counter equal to  $3n$ .

## **Data**

This is the data block following the information block. The type of data in the data block depends on the type of information requested by the computer.

### **Image data**

Image data blocks sent in response to the ESC G (Start scanning) command

### **ID information data**

Data, including the scanner function level, sent in response to the ESC I (Request ID) command

### **Scanner state data**

Data on the scanner's current settings and parameters sent in response to the ESC S (Request condition) command

### **Extended status data**

Data on the scanner's option settings sent in response to the ESC f (Request extended status) command

### **Note:**

*The data block sent in response to the ESC F (Request status) command consists of the information block only; no data block is included. Because of this, the byte counter is set to 0 (00H, 00H). Use this command when you need to check only the contents of the status byte.*

## **Image data**

This is the scanned image data sent in response to the ESC G (Start scanning) command. The amount of data sent depends on the current scanner settings.

The commands that determine the amount of data are the ESC D (Set data format) command and the ESC A (Set scanning area) command.

## **ID information data**

This is data sent in response to the ESC I (Request ID) command. This data includes the following.

The scanner function level

The available resolutions

The maximum scannable area

The basic format of this data is as follows:

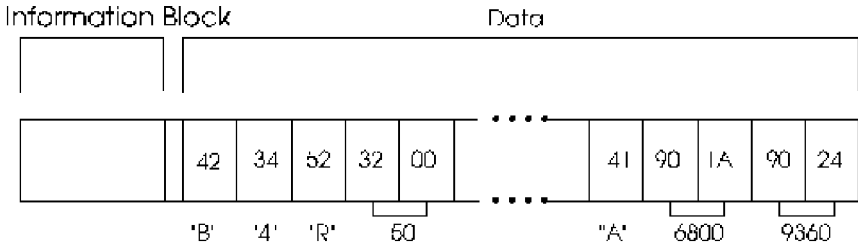

The first two bytes show the scanner function level, in ASCII character format. The scanner function level tells you which commands are supported by the attached scanner.

Following these two bytes are the available scanner resolutions, described in 3-byte groups. Multiple resolutions are listed, and the available resolutions differ according to scanner model. The values listed are the available values for the parameter in the ESC R (Set resolution) command. The values listed can be assigned to both the main scan and sub scan; the main scan and sub scan can be set independently of one another. The final 5 bytes are the maximum scannable area when the maximum resolution and 100% zoom are selected. This value also varies by scanner model. This value, along with the maximum resolution value, are the maximum parameters available with the ESC A command.

## Scanner state data

This is the data sent in response to the ESC S (Request condition) command. The example below is for a B4-level scanner.

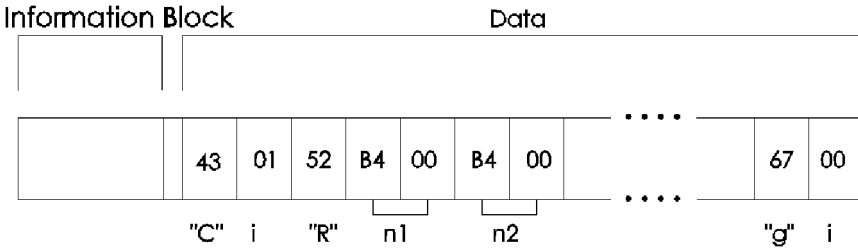

The first two bytes are the ESC C (Set color) command's parameters.

The next 5 bytes are the ESC R (Set scanning resolution) command's parameters.

The last two bytes are the ESC g (Set scanning mode) command's parameters.

## Transfer order

The recommended order of data transfer for each type of data is outlined in the flow charts below.

## Image data

### Monochrome, color line, and color byte scanning

Use when sending monochrome and color line scanning data or color byte scanning data. This includes monochrome scanning when a dropout color is selected.

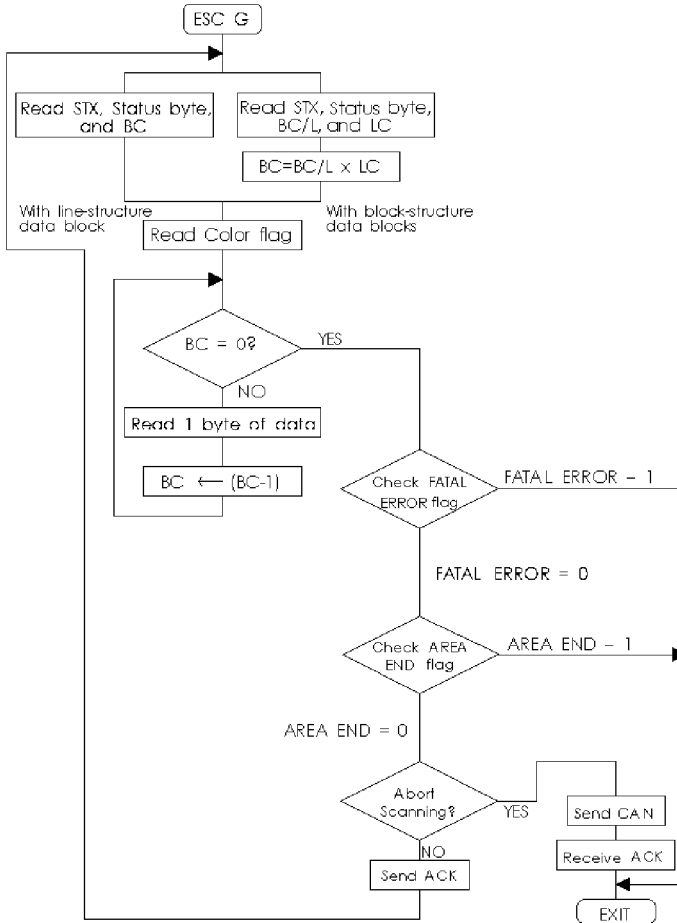

## Color page scanning

Use when sending color page data.

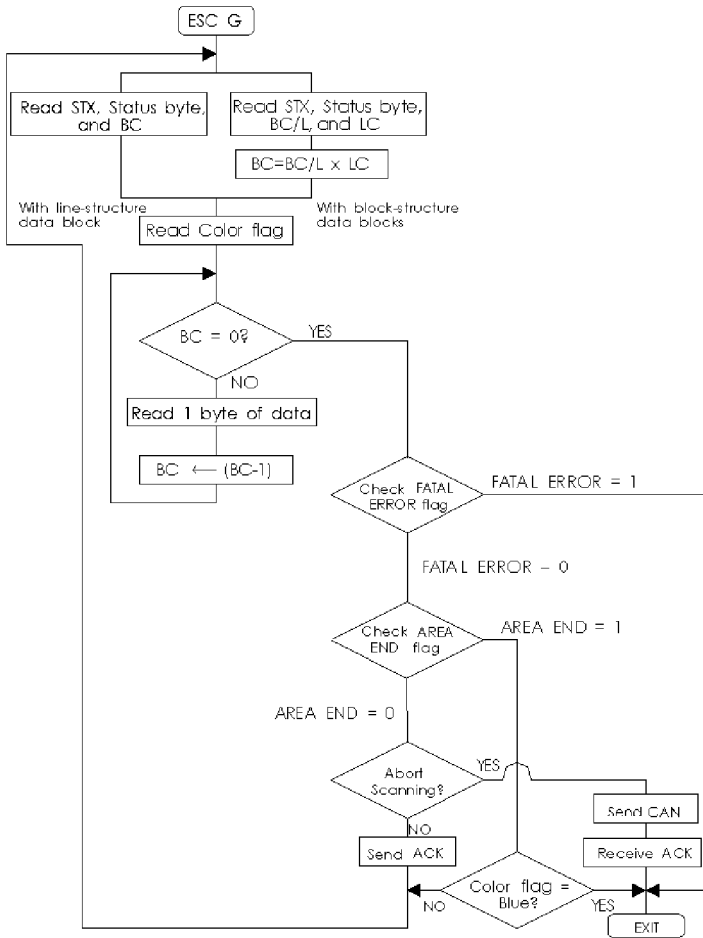



## Single data blocks

Use when you expect single data blocks in response to the ESC I (Request ID) command, the ESC S (Request condition) command, the ESC F (Request status) command, and the ESC f (Request extended status) command.

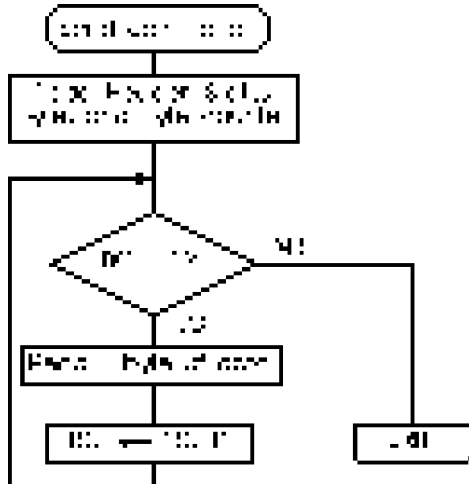

---

## Scanning Area

The following commands affect the scanning area: the ESC R (Set resolution) command, the ESC H (Set zoom) command, and the ESC A (Set scanning area) command. The parameter values in the ID information are used in these commands. The relationship between these commands and the scanning area is explained below.

## **Resolution, zoom, and maximum scannable area**

The ID information provides you the following values.

$R_{MAX}$  (in dpi) : The maximum scannable area available

$X_{MAX}$  (in dots) : The maximum main scan value (at the maximum resolution, 100% zoom)

$Y_{MAX}$  (in dots) : The maximum sub scan value (at the maximum resolution, 100% zoom)

Based on these values, you can calculate the maximum scannable area for various resolution and zoom settings according to the following formulas.

Main scan (in dots)

$$n_x = INT \left( \frac{X_{MAX}}{R_{MAX}} \times \frac{R_X \times H_X}{100} \right)$$

Sub scan

$$n_y = INT \left( \frac{Y_{MAX}}{R_{MAX}} \times \frac{R_Y \times H_Y}{100} \right)$$

Based on these values, the limits of the parameters for the ESC A command are as follows:

$n_1$  (main scan skip length) :  $0 \leq n_1 \leq n_x - 8$

$n_2$  (sub scan skip length) :  $0 \leq n_2 \leq n_y - 1$

$n_3$  (main scan reading length) :  $8 \leq n_3 \leq 8 \times INT \left( \frac{n_x - n_1}{8} \right)$

$n_4$  (sub scan reading length) :  $1 \leq n_4 \leq n_y - n_2$

$n_1 + n_3 \leq n_x$

$n_2 + n_4 \leq n_y$

**Note:**

The limits of the  $n_3$  parameter depend on your scanner model. See your scanner's manual for details.

The main scan reading length ( $n_3$ ) must always be set in exact multiples of eight (8-dot units equal units of 1 byte). The main scan skip length ( $n_1$ ), sub scan skip length ( $n_2$ ), and sub scan reading length ( $n_4$ ) can be set in 1-dot increments.

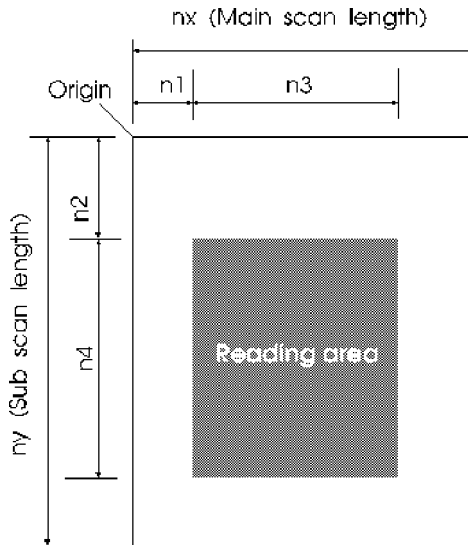

Use the above values to set the scanning area with the ESC R, ESC H, and ESC A commands.

**Note:**

*The ESC A command sets the length (number of lines) of the sub scan reading length. However, you should always check the area end flag in the status byte to confirm whether the current data block is the final block. Do not rely solely on your calculations from the ESC A command.*

# Setting the scanning area

Use the ESC R, ESC H, and ESC A commands to set the scanning area. The diagram below shows the relationship between the ESC R, ESC H, and ESC A command parameters and the scanning area.

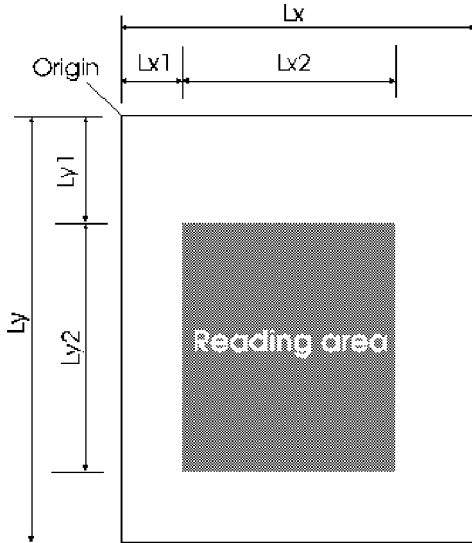

$R_X$  : Main scan resolution (in dpi)

$R_Y$  : Sub scan resolution (in dpi)

$H_X$  : Main scan zoom (in %)

$H_Y$  : Sub scan zoom (in %)

After setting the above values, determine the ESC A parameters based on the following formulas:

$$n_1 = INT \frac{L_{X1} \times R_X \times H_X}{100}$$

$$n_2 = INT \frac{L_{Y1} \times R_Y \times H_Y}{100}$$

$$n_3 = 8 \times INT \left( \left( \frac{L_{X2} \times R_X \times H_X}{100} \right) \times \frac{1}{8} \right)$$

$$n_4 = INT \frac{L_{Y2} \times R_Y \times H_Y}{100}$$

$$n_1 + n_3 \leq INT \left( \left( \frac{\text{maximum main scan length}}{\text{maximum resolution}} \right) \times \left( \frac{R_X \times H_X}{100} \right) \right)$$

$$n_2 + n_4 \leq INT \left( \left( \frac{\text{maximum sub scan length}}{\text{maximum resolution}} \right) \times \left( \frac{R_Y \times H_Y}{100} \right) \right)$$

## Image trimming (1)

This section explains how to trim a rough image, and how to use the ESC R, ESC H, and ESC A commands to rescan at the same resolution and zoom values. This is useful when you want to check the image from within your software and then reset the scanning area for the next scan.

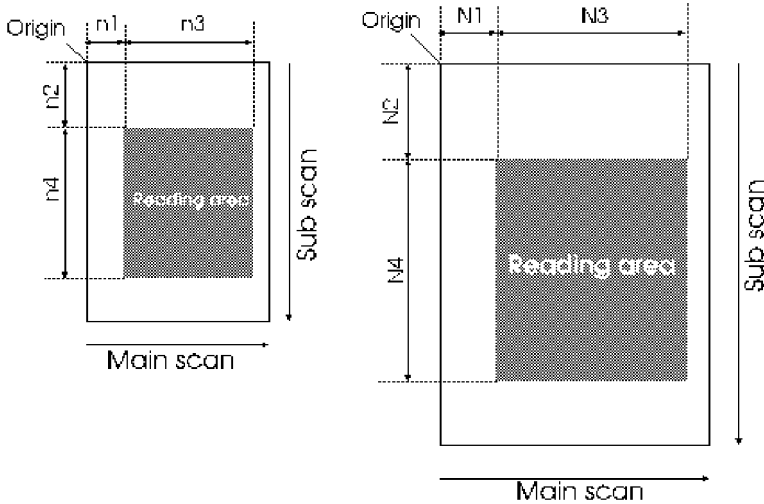

### Rough scanned image

$R_{X1}$  : Main scan resolution (dpi)  
 $R_{Y1}$  : Sub scan resolution (dpi)  
 $H_{X1}$  : Main scan zoom (%)  
 $H_{Y1}$  : Sub scan zoom (%)

$n_1$  : main scan skip length  
 $n_2$  : sub scan skip length  
 $n_3$  : main scan reading length  
 $n_4$  : sub scan reading length

### Image after trimming

$R_{X2}$  : Main scan resolution (dpi)  
 $R_{Y2}$  : Sub scan resolution (dpi)  
 $H_{X2}$  : Sub scan zoom (%)  
 $H_{Y2}$  : Sub scan zoom (%)

$N_1$  : main scan skip length  
 $N_2$  : sub scan skip length  
 $N_3$  : main scan reading length  
 $N_4$  : sub scan reading length

## Determining setting values after trimming

After trimming an image, you should resend the ESC A command using the following parameters.

$$N_1 = INT \left( \frac{n_1 \times R_{X2} \times H_{X2}}{R_{X1} \times H_{X1}} \right)$$

$$N_2 = INT \left( \frac{n_2 \times R_{Y2} \times H_{Y2}}{R_{Y1} \times H_{Y1}} \right)$$

$$N_3 = 8 \times INT \left( \left( \frac{n_3 \times R_{X2} \times H_{X2}}{R_{X1} \times H_{X1}} \right) \times \frac{1}{8} \right)$$

$$N_4 = INT \left( \frac{n_4 \times R_{Y2} \times H_{Y2}}{R_{Y1} \times H_{Y1}} \right)$$

$$N_1 + N_3 \leq INT \left( \frac{(\text{maximum main scan length})}{(\text{maximum resolution})} \times \frac{R_X \times H_X}{100} \right)$$

$$N_2 + N_4 \leq INT \left( \frac{(\text{maximum sub scan length})}{(\text{maximum resolution})} \times \frac{R_Y \times H_Y}{100} \right)$$

The parameters for the ESC R, ESC H, and ESC A command should be set to the following.

ESC R :  $n_1 = R_{X2}$ ,  $n_2 = R_{Y2}$

ESC H :  $i_1 = H_{X2}$ ,  $i_2 = H_{Y2}$

ESC A :  $n_1 = N_1$ ,  $n_2 = N_2$ ,  $n_3 = N_3$ ,  $n_4 = N_4$

## Image trimming (2)

This section explains how to use the ESC R, ESC H, and ESC A commands to print a trimmed image on your printer.

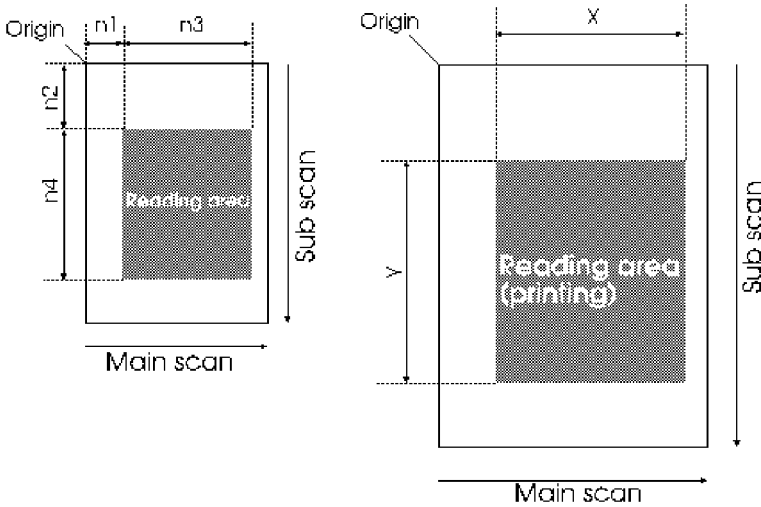

### Rough scanned image

$R_{X1}$  : Main scan resolution (dpi)  
 $R_{Y1}$  : Sub scan resolution (dpi)  
 $H_{X1}$  : Main scan zoom (%)  
 $H_{Y1}$  : Sub scan zoom (%)

### Printing size after trimming

$R_{PX}$  : Printer resolution (dpi)  
 main scan (horizontal)  
 $R_{PY}$  : Printer resolution (dpi)  
 sub scan (vertical)

Main scan skip length (inches):

$$L_{X1} = \frac{n1 \times 100}{R_{X1} \times H_{X1}}$$

Sub scan skip length (inches):

$$L_{Y1} = \frac{n2 \times 100}{R_{Y1} \times H_{Y1}}$$

Main scan reading length (inches):

$$L_{X2} = \frac{n3 \times 100}{R_{X1} \times H_{X1}}$$

Sub scan reading length (inches):

$$L_{Y2} = \frac{n4 \times 100}{R_{Y1} \times H_{Y1}}$$



## Determining the setting values for printing

Based on the size of the image you plan to print and on the resolution of the printer, use the following formulas to determine the final scanning settings.

$$\text{Main scan zoom (\%):} \quad H_X = \frac{X \times 100}{L_{X2}}$$

$$\text{Sub scan zoom (\%):} \quad H_Y = \frac{Y \times 100}{L_{Y2}}$$

$$N_1 = INT \left( \frac{n_1 \times R_{PX} \times H_X}{R_{X1} \times H_{X1}} \right) \quad N_2 = INT \left( \frac{n_2 \times R_{PY} \times H_Y}{R_{Y1} \times H_{Y1}} \right)$$

$$N_3 = 8 \times INT \left( \left( \frac{n_3 \times R_{PX} \times H_X}{R_{X1} \times H_{X1}} \right) \times \frac{1}{8} \right) \quad N_4 = INT \left( \frac{n_4 \times R_{Y2} \times H_Y}{R_{Y1} \times H_{Y1}} \right)$$

$$N_1 + N_3 \leq INT \left( \frac{(\text{maximum main scan length})}{(\text{maximum resolution})} \times \frac{R_X \times H_X}{100} \right)$$

$$N_2 + N_4 \leq INT \left( \frac{(\text{maximum sub scan length})}{(\text{maximum resolution})} \times \frac{R_Y \times H_Y}{100} \right)$$

The parameter values for the ESC R, ESC H, and ESC A commands then become as follows:

$$\text{ESC R :} \quad n_1 = R_{PX}, n_2 = R_{PY}$$

$$\text{ESC H :} \quad i_1 = H_X, i_2 = H_Y$$

$$\text{ESC A :} \quad n_1 = N_1, n_2 = N_2, n_3 = N_3, n_4 = N_4$$

### **Note:**

*On scanners that can respond to printers and other various output devices, you can set the  $R_{PX}$  and  $R_{PY}$  values to match the horizontal and vertical resolution of your target printer.*

---

## **Error Processing**

EPSON scanners have four types of potential errors: command errors, communications errors, system errors, and option errors. An option error can occur only with scanner models on which the optional Automatic Document Feeder or Transparency Unit can be installed.

When an error occurs, the LED indicator displays the error type. For details, see the scanner's user's manual.

### **Command error**

This error occurs when the scanner receives an incorrect command or a command with incorrect parameters.

#### *Cause:*

The scanner receives an undefined command.

The scanner receives a command with incorrect parameters.

#### *Scanner's response:*

The scanner returns a NAK code to the computer, ignores the incorrect command or parameters, and waits for the next command.

#### *Error recovery procedure:*

Send a correct command; the scanner then clears the error condition.

### **Communications error**

A communication error occurs when the scanner and computer cannot communicate properly.

#### *Cause:*

The interface is disconnected or not connected properly.

The communications (interface) settings are incorrect.

*Scanner's response:*

The lamps turn off and the scanner stops moving.

The scanner stops accepting commands.

*Error recovery procedure:*

After correcting the communications problem, perform one of the following.

Turn the scanner off and then back on again.

Press the reset button (if the scanner model has a reset button).

Set the parallel interface's  $\overline{\text{INIT}}$  signal to LOW.

Send a device reset message on your SCSI line.

Set the SCSI's reset line to active.

## **System error**

The scanner itself is not functioning properly.

*Cause:*

The lamps are disconnected or burned out.

The shipping screw has not been removed from the carriage (the scanner cannot perform the carriage initialization procedure).

The scanner is broken.

During scanning, an option error was detected (cover open, paper jam, etc.).

*Scanner's response:*

The lamps turn off and the scanner stops moving.

Bit 7 (error flag) of the status byte is set to “1.”

The appropriate bit in the extended status byte is set.

The scanner only accepts these commands: ESC F, ESC f, and ESC @.

***Error recovery procedure:***

After correcting the cause of the problem, perform one of the following.

Turn the scanner off and then back on again.

Press the reset button (if the scanner model has a reset button).

Send the ESC @ command.

Set the parallel interface's  $\overline{\text{INIT}}$  signal to LOW.

Send a device reset message on your SCSI line.

Set the SCSI's reset line to active.

***Option error***

When an option is installed and the ESC e (Control option) command is enabled, this error occurs if the option does not operate properly.

***Cause:***

An option error is detected (cover open, paper jam, etc.).

***Scanner's response:***

Bit 7 (error flag) of the status byte is set to “1.”

The appropriate bit in the extended status byte is set.

***Error recover procedure:***

Correcting the cause of the error clears the error condition.

---

## **Function Level and Commands**

Each function level builds on the previous level, so all commands and parameters in previous levels are included in higher levels. Extended commands are available regardless of function level.

### ***Using the function level***

Higher function levels include all the commands of lower function levels. Your programs should always check the function level of the connected scanner and should send only those commands available on that level.

***Note:***

*All settings have initial default values, and some models have settings that can be set using DIP switches or the control panel. However, settings made using commands take precedence over these other setting methods; to avoid errors and confusion, it is recommended you make necessary settings using commands whenever possible.*

## Commands and function level table

The following table shows which commands are available at each function level.

Command type	Command name	Command	Function Level
Execution commands	Request ID	ESC I	B1
	Request status	ESC F	B1
	Request extended status	ESC f	Extended
	Request condition	ESC S	B1
	Start scanning	ESC G	B1
Data format commands	Set data format	ESC D	B1
	Set resolution	ESC R	B1
	Set zoom	ESC H	B2
	Set scanning area	ESC A	B1
	Set color	ESC C	B1*
	Set data order	ESC K	B5, A5
Image setting commands	Set brightness	ESC L	B2
	Set gamma correction	ESC Z	B2*
	Download gamma table	ESC z	B4
	Set sharpness	ESC Q	B4
Image processing commands	Set halftoning mode	ESC B	B1*
	Download dither pattern	ESC b	B4
	Set color correction	ESC M	B3
	Download color correction	ESC m	B4
	Set auto area segmentation	ESC s	A5
Auxiliary commands	Set scanning mode	ESC g	B4
	Set line counter	ESC d	B4
	Control option	ESC e	Extended
	Eject document	FF	Extended
	Initialize the scanner	ESC @	B2
	Abort scanning	CAN	B1

\* The parameters for these commands differ by function level.

## Function level and commands

The commands added at each function level are listed in the table below.

Function level	Command
B1	ESC G (Start scanning) ESC I (Request ID) ESC F (Request status) ESC S (Request condition) ESC R (Set resolution) ESC A (Set scanning area) CAN (Abort scanning) ESC D (Set data format) ESC C (Set color) ESC B (Set halftoning mode)
B2	ESC L (Set brightness) ESC Z (Set gamma correction) ESC H (Set zoom) ESC @ (Initialize the scanner)
B3	ESC M (Set color correction)
B4	ESC z (Download gamma table) ESC Q (Set sharpness) ESC b (Download dither pattern) ESC g (Set scanning mode) ESC d (Set line counter) ESC m (Download color correction)
B5, A5	ESC K (Set data order)
A5	ESC s (Set auto area segmentation)
Extended	ESC f (Request extended status) ESC e (Control option) FF (Eject document)

## ***Items not affected by function level***

Although higher command levels include all the previous commands of lower command levels, the parameters for commands used to set the scanning area (ESC R, ESC H, ESC A) are independent of function level. These parameters are determined by the physical characteristics of each scanner; obtain the values available for these parameters by checking the ID information.

### Resolution

The resolutions available vary by scanner model and can be obtained from the ID information returned by the scanner when you send the Request ID command. If you use the ESC R command to specify a resolution that is not available on the connected scanner, a command error results. The last resolution listed in the ID information is the maximum resolution available on the connected scanner.

### Maximum scannable area

The maximum scannable area (# of main scan dots  $\times$  # of sub scan dots) you can set with the ESC A command differs by scanner model. This value can be calculated from the maximum resolution and maximum area values found in the ID information.

### Zoom setting increments (1% or 10%)

You can adjust the zoom value from 50% to 200%. However, the minimum increment you can use to adjust the zoom value differs by scanner model, and is either 1% or 10%. If you make a zoom setting that is not a multiple of 10% on a scanner that only allows 10% increments, the scanner rounds the setting to the nearest increment of 10%. (The scanner either corrects or deletes image data to conform with the ESC A setting. Although this can result in the image differing slightly from what you expect, you do not need to take this into consideration within your program.)

### Options

To determine whether an option is installed on the connected scanner, send the ESC F command and check the option flag in the resulting status byte. You should also use the ESC f command to determine the maximum scannable area when the option is installed.



---

## **Typical Programming Errors and Solutions**

This section lists several concrete examples of programming errors, their causes, and sample solutions to these problems.

### **Problem:**

*The scanner does not scan correctly when a scanner with a different maximum scannable area is connected.*

#### Cause

You relied on the default maximum scannable area setting instead of setting the scanning area with the ESC A command. The maximum scannable area differs by scanner model.

#### Solution

Always set the scanning area with the ESC A command.

Use the ESC I command to determine the current scanner's maximum scannable area, and make sure the parameters in the ESC A command do not exceed those values.

**Problem:**

*When connecting a different scanner model in your SCSI daisy chain, an error message such as the following appears; “The EPSON scanner is not connected.”*

Cause

When you sent the SCSI inquiry command, the computer checked the scanner’s model name in the Vendor Unique Parameter.

Solution

When checking the Vendor Unique Parameter, only check the following underlined items:

...“EPSON”,20H,SCANNER,20H“GT-XXXX”... (B1–B4)

...“EPSON”,20H,20H,20H,SCANNER,20H“GT-XXXX”... (B5, A5)

This ensures that information on a particular model name is not checked by your program.

**Problem:**

*Although you have attached a new scanner capable of a higher resolution, you cannot achieve that resolution when scanning.*

Cause

Your program is still using the scanning resolution settings you obtained from the previous scanner model.

Solution

Use the ESC I command to obtain the scanning resolution values each time you scan.

**Problem:**

*After connecting a scanner with a higher function level than the previous scanner, the new scanner does not operate properly.*

Cause

Although you used the ESC I command to obtain the function level information, your program was set up to work only when the function level was the same as the previous scanner.

Solution

EPSON scanner function levels are designed so that higher levels encompass all the commands of lower levels. Change your program so it works with scanners of equal level *or higher*.

**Problem:**

*The speed of image data transfer remains the same, whether you use a SCSI or bi-directional parallel interface.*

Cause

Your program is writing each line of image data to your hard disk as the data is received.

Solution

When using scanners of B4 level or higher, always use block data transfer.

**Problem:**

*The scanner scans properly when you use a bi-directional parallel interface, but when you switch to SCSI, the scanner no longer operates properly.*

Cause

During block data transfer mode, your program does not read the entire block at one time, but performs multiple read commands for each data block.

Solution

Change your program so it reads the entire block in one read operation.

**Problem:**

*After using a scanner option (Automatic Document Feeder or Transparency Unit), a different program attempts scanning. Although the second program tries to scan without using the option, the option remains operational.*

Cause

Your program did not exit option mode upon completion.

Solution

Always exit option mode upon program completion.

**Problem:**

*When connecting a different scanner model, a time-out occurs on your computer and you can no longer scan.*

Cause

The time required for the initialization process and for the preparation time when you send an ESC G command differs by scanner model. The new scanner model took longer than the previous scanner.

Solution

Make sure you provide enough time on your time-out clock to handle all scanner models (35 seconds should be enough).

**Problem:**

*When writing data from a GT-6000 or GT-4000 to a magneto-optical disk, an interface error occurs on the scanner.*

Cause

On the GT-6000/4000, the scanner produces an interface error if no handshake response is received within 30 seconds. If a writing operation takes longer than 30 seconds, this error occurs.

Solution

Adjust the size of your data buffer so that no writing operation takes longer than 30 seconds.

Here are some additional items to consider when you write a scanner program.

## *General*

- ❑ Always reset the scanner at the beginning and end of your programs
- ❑ Use the ESC @ command to reset the scanner. This allows you to use the same program with different interfaces.
- ❑ The time required for resetting differs by scanner model. Because of this, you should either disable your computer's time-out or set the time-out clock to 30 seconds or more.

## *Parallel interface*

- ❑ If your program sends a command immediately after resetting the scanner and gets a BUSY signal, wait at least 1 ms and send the command again.

## *Option*

- ❑ Always send a FF command after you complete reading of a document from an ADF.

## *Using the ESC I command*

- ❑ Always check the scanner information at the beginning of your program. (This is not necessary if you provide a different driver for each scanner model.)

## *About the function level*

- ❑ Since higher-level scanners contain all the functionality of lower-level scanners, no errors occur when you use a low-level scanner program on a higher-level scanner.
- ❑ When running a program designed for a high-level scanner on a lower-level scanner, make sure your program does not send any unsupported commands; otherwise, an error results.



---

## **Summary of the Scanner Commands**

Five types of scanner commands are used with EPSON scanners. In addition, four control codes are used for handshaking. The five command types are:

<b>Execution:</b>	Requests the scanner to send back data
<b>Data form definition:</b>	Specifies the format of data to be sent from the scanner
<b>Image definition:</b>	Sets image modes
<b>Image processing:</b>	Specifies any enhancement processes to be used
<b>Auxiliary:</b>	Helps control the scanner

### *Execution commands*

These commands obtain data from the scanner.

Request ID	ESC I
Request status	ESC F
Request extended status	ESC f
Request condition	ESC S
Start scanning	ESC G

### *Data form definition commands*

These commands specify the format of image data and data transfer.

Set color	ESC C
Set data format	ESC D
Set resolution	ESC R
Set zoom	ESC H
Set scanning area	ESC A
Set data order	ESC K



## *Image definition commands*

Set conditions for image reading with these commands.

Set brightness	ESC L
Set gamma correction	ESC Z
Download gamma table	ESC z
Set sharpness	ESC Q

## *Image processing commands*

Process images before data transfer with these commands.

Set halftoning mode	ESC B
Download dither pattern	ESC b
Set color correction	ESC M
Download color correction	ESC m
Set auto area segmentation	ESC s

## *Supplemental commands*

Operate the scanner mechanism with these commands.

Initialize the scanner	ESC @
Set line counter	ESC d
Set scanning mode	ESC g
Control option	ESC e
Eject document	FF

## *Control codes*

Perform handshaking between the computer and scanner using these commands.

Header	STX
Abort scanning	CAN
Normal response	ACK
Abnormal response	NAK

---

## **Format of the Command Reference**

The command explanations in this chapter are each divided into six parts. The command explanations are given in the sequence indicated in the command summary table on the preceding page. (For recommendations on how to use the commands, see Chapter 2.)

### **Command title**

Indicates the name and function of the command

### **Command format**

Shows the structure of the command and any associated parameters

**Command:** Shows the command code sequence in ASCII, decimal, and hexadecimal formats

**Parameter:** Lists parameters, if applicable

Some commands require parameters to be sent after the command has been accepted by the scanner. Commands and parameters are listed separately if the handshaking method requires they be sent separately.

Parameters denoted by *n* are two-byte parameters (ranging from 0 to 65,535 decimal), with the lower byte preceding the higher byte. Where necessary, the lower byte is denoted by L and higher byte by H.

Parameters denoted by *i* are one-byte parameters (ranging from 0 to 255 decimal).

Parameters denoted by *d* are signed one-byte parameters (ranging from -127 to 127 decimal).

**Handshaking**

Shows a diagram indicating the handshaking method used with the command. See Chapter 2 for details on handshaking.

**Parameter range**

Shows the range and explains the meanings of parameters, when relevant. This section also lists the default values.

**Explanation**

This gives a detailed explanation of the effect and appropriate usage of the command.

**Functional level**

Lists values such as B1 and B4 on the command line and in the parameter range to indicate the ESC/I function level of the command. See Chapter 2 for details.

---

# Execution Commands

ESC I	Request identity					
<b>Format:</b>	<b>B1</b>	<b>B2</b>	<b>B3</b>	<b>B4</b>	<b>B5</b>	<b>A5</b>
Command: ASCII:	<b>ESC</b>	<b>I</b>				
Decimal:	27	73				
Hexadecimal:	1B	49				
Parameter:	(none)					
Handshaking:						

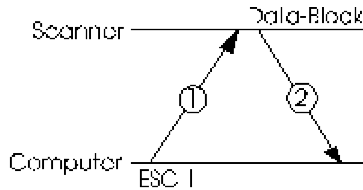

- 1 ESC I command
- 2 data block

## Explanation:

This command requests the scanner to send back a data block that identifies the properties of the scanner. When this command is received, the scanner sends the following information.

- ❑ The scanner's functional level identification
- ❑ The resolution settings available
- ❑ The maximum scannable area at the maximum resolution and 100% zoom (main scan by sub scan in dots)

For a more detailed explanation on using the **ESC I** command and the contents of the returned data block, see Chapter 2 and Appendix B.

The length of the data block varies depending on the scanner model. The host computer should check the byte counter.

### **Contents of the ESC I (identity) data block**

The contents of the **ESC I** data block for each scanner model are listed in Appendix B.

**Format:**

B1 B2 B3 B4 B5 A5

Command: ASCII:           ESC    F

                  Decimal:       27    70

                  Hexadecimal:  1B    46

Parameter:                    (none)

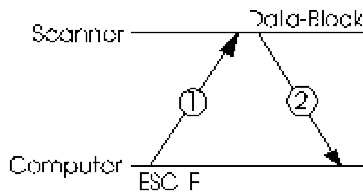
**Handshaking:**

- 1 ESC F command
- 2 data block

**Explanation:**

When this command is received, the scanner sends a data block indicating the current status of the scanner. The current status can be determined by reading the flags of the status byte. See Chapter 2 for details on the status byte.

The data block contains only an information block, and is not followed by data. Because of this, the value of the byte counter is always null.

## Contents of the ESC F (status) data block

Order of byte	Data (in hex)	Contents	Explanation
1	02	<b>STX</b> code	Header: indicates the beginning of the data block
2	xx	Status	Status byte: indicates the status of the scanner
3	00	0 bytes	Byte counter: indicates the number of bytes of data (The null value indicates that no data follows)
4	00		

**Note:**

*The numerical value of the byte counter consists of two bytes, and the lower byte precedes the higher byte.*

**Format:**

EXT

Command: ASCII:           ESC    f  
                  Decimal:       27    102  
                  Hexadecimal:  1B    66

Parameter:                    (none)

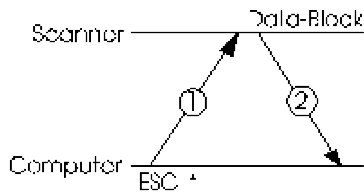
**Handshaking:**

- 1 ESC f command
- 2 Data block

**Explanation:**

When this command is received, the scanner sends a data block indicating the current status of the scanner and any optional equipment. The current status can be determined by reading the flags of the status byte and the following bytes of status data.



## Contents of the ESC f (extended status) data block

Order of byte	Data (in hex)	Contents	Explanation
1	02	<b>STX</b> code	Header: indicates the beginning of the data block
2	xx	Status byte	Byte: indicates the status of the scanner
3	00	33 bytes	Byte counter: indicates the number of bytes of status data
4	00		
5	xx	Scanner status	"1" in bit 7 indicates a fatal scanner error
6	xx	ADF status	Bit 7: IST Bit 6: EN Bit 5: ERR Bit 3: PE Bit 2: PJ Bit 1: OPN
7	xx	Maximum area (4 bytes)	Indicates maximum scanning area with ADF
8	xx		
9	xx		
10	xx		
11	xx	T.P.U. status	Bit 7: IST Bit 6: EN Bit 5: ERR Bit 1: OPN
12	xx	Maximum area (4 bytes)	Indicates maximum scanning area with Transparency Unit
13	xx		
14	xx		
15	xx		
16–36	00	Reserved (22 bytes)	Reserved bytes

IST: '1' indicates option is installed  
 EN: '1' indicates option is enabled (otherwise, it is disabled)  
 ERR: Logical OR of PE, PJ, and OPN  
 PE: '1' indicates paper empty  
 PJ: '1' indicates paper jam  
 OPN: '1' indicates cover open

### *Note:*

*The numerical value of the byte counter consists of two bytes, with the lower byte preceding the higher byte.*

**ESC S****Request condition****Format:**

B1 B2 B3 B4 B5 A5

Command: ASCII:           ESC   S

Decimal:           27    83

Hexadecimal:   1B   53

Parameter:            (none)

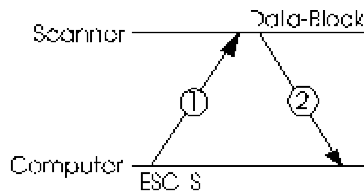
**Handshaking:**

- 1 ESC S command
- 2 Data block

**Explanation:**

This command asks the scanner to send back a data block that contains the current parameter values set in the scanner.

The structure of returned values is identical to the structure of the command parameters. The number of command functions included in the data block depends on the function level and the model of the scanner.

**Contents of the ESC S (condition) data block**

The contents of the ESC S data block are listed by model in Appendix B.

## ESC G

Start scanning

Format:

B1 B2 B3 B4 B5

Command: ASCII:           ESC    G

Decimal:           27     71

Hexadecimal:   1B     47

Parameter:           (none)

### Handshaking:

The handshaking procedures are different for the monochrome mode, color page sequence mode, color line sequence, and color byte sequence mode. See Chapter 2 for more details on handshaking.

### Monochrome mode (one time scanning)

Monochrome image data is sent as a page. When a dropout color is specified, the color flag of the status byte indicates the specified dropout color.

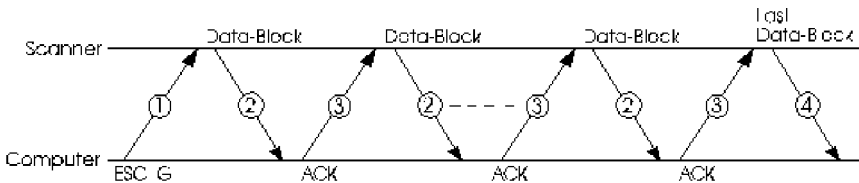

- 1 **ESC G** command
- 2 Data block (image data for one block)
- 3 **ACK** code
- 4 Last data block (last line)

- Steps 2 and 3 should be repeated for the number of lines (minus 1) specified for the image, until the last data block is received.
- Do not send an **ACK** code after the last data block.

### Color page sequence mode (three pass scanning)

The color image data is sent as a set of three primary color pages.

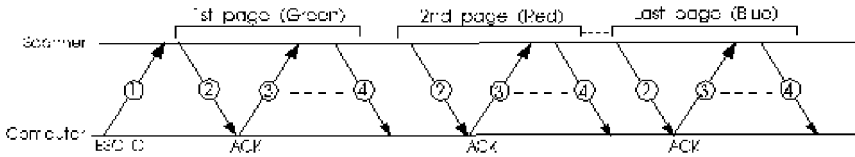

- 1 **ESC G** command
- 2 Data block (image data for one block)
- 3 **ACK** code
- 4 Last data block (last line of each color page)

- ❑ Steps 2 and 3 should be repeated for the number of lines (minus 1) specified for each color page of green, red, and blue until the last data block is encountered.
- ❑ Do not send the **ACK** code after the last data block of each color page.

### Color line sequence mode (one pass scanning)

The color image data is sent as one page, and three primary colors are sent for each line.

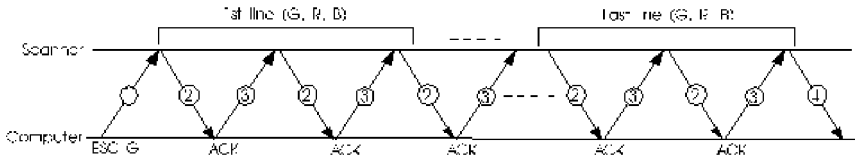

- 1 **ESC G** command
- 2 Data block (image data for one line)
- 3 **ACK** code
- 4 Last data block (last line of the page)

- ❑ Steps 2 and 3 should be repeated for the three colors for the number of lines (minus 1) specified for the image until the last data block is encountered.
- ❑ Do not send the **ACK** code after the last data block (the last blue data).

### Color byte sequence mode

Handshaking:

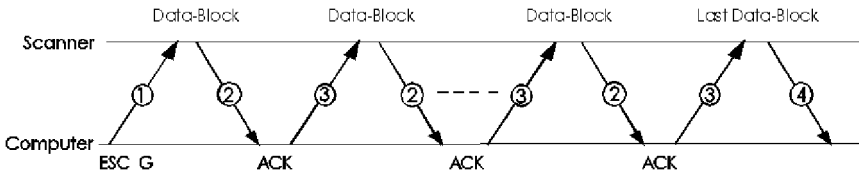

- 1 **ESC G** command
- 2 Data block (image data for one block)
- 3 **ACK** code
- 4 Last data block (last line of the page)

- ❑ Steps 2 and 3 should be repeated for the number of lines (minus 1) specified for the image until the last data block is encountered.
- ❑ Do not send the **ACK** code after the last data block.

## Explanation:

When this command is received, the scanner starts a scanning operation (image reading) for the specified reading area, and sends the image data to the host computer as data blocks.

Image data of one line (one main scan of data) is sent as a data block, and a data block is sent for each sub scan reading length.

When the computer receives a data block, it should send an **ACK** code to indicate that it has accepted the data block and to prompt the scanner to send the next data block. If the computer fails to send an **ACK** code within 30 seconds after it receives a data block, an interface error occurs in the scanner.

When the computer receives the last data block (the last line of the image), it should not send the **ACK** code. If it sends an **ACK** code after the last data block, a command error occurs in the scanner.

### Note:

- ❑ After accepting the last data block, the host computer should not send an **ACK** code to the scanner.
- ❑ The area end flag of the status byte is set to 1 in the last data block.

## Aborting a scanning operation

Scanning can be aborted by sending a **CAN** code in place of an **ACK** code after the computer receives a data block.

When the **CAN** code is received, the scanner returns an **ACK** code in response, then terminates the remaining scanning operation.

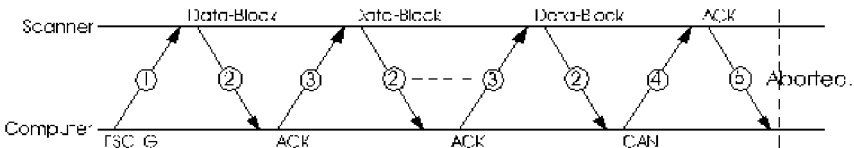

- 1 **ESC G** command
- 2 Data block (image data for one block)
- 3 **ACK** code (acceptance of the data block)
- 4 **CAN** code (abort scanning)
- 5 **ACK** code

Sending the **CAN** code does not reset the parameter settings in the scanner, unless the **ESC @** (initialize the scanner) command is sent, or the scanner is turned off and back on. Settings made with the control panel remain in effect unless corresponding commands are sent to override them.

To restart scanning, send the **ESC G** command again. It is not possible to resume scanning from where it was aborted. The standard procedures of scanner control should be repeated from the beginning; do not send only the **ESC G** command to restart.

**Note:**

*When scanning is terminated by the **CAN** code, the carriage returns to the home position. To start another scanning operation, wait until the scanner is ready. The **BUSY** line on the bi-directional parallel interface, or the **DTR** line on the serial interface, indicates when the scanner is ready, and the **READY** light on the scanner's control panel comes on.*

---

## Data Form Definition Commands

**ESC C**

**Set color mode**

---

Format:

B1 B2 B3 B4 B5 A5

Command:

ASCII:       ESC    C

Decimal:       27    67

Hexadecimal:  1B    43

Parameter:

i

### Handshaking:

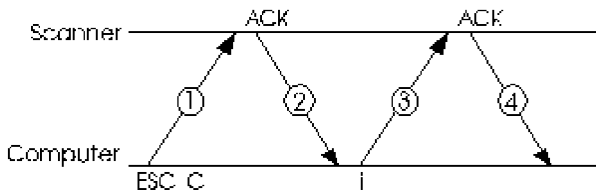

- 1 **ESC C** command
- 2 **ACK** code
- 3 Parameter (i)
- 4 **ACK** code



**Parameter range:**

i=00H (0):	Monochrome scanning (standard), no dropout color specified B1 B2 B3 B4 B5 A5
i=10H (16):	Monochrome scanning, dropout color is Red B2 B3 B4 B5
i=20H (32):	Monochrome scanning, dropout color is Green B2 B3 B4 B5
i=30H (48):	Monochrome scanning, dropout color is Blue B2 B3 B4 B5
i=01H (1):	Color scanning (color sequence is G→R→B) of page sequence mode B1 B2 B3 B4 B5
i=02H (2):	Color scanning (color sequence is G→R→B) of line sequence mode B3 B4 B5
i=03H (3):	Color scanning (color sequence is G→R→B) of byte sequence mode B5
i=11H (17):	Color scanning (color sequence is R→G→B) of page sequence mode B5
i=12H (18):	Color scanning (color sequence is R→G→B) of line sequence mode B5
i=13H (19):	Color scanning (color sequence is R→G→B) of byte sequence mode B5

Default value: i = 00H

## **Explanation:**

This command specifies the reading color (color or monochrome), the page, line, or byte sequence mode in color reading, and the dropout color in monochrome reading.

### Color page sequence reading

The scanner scans the document three times, for green, red, and blue, and produces three pages of image data that can be overlaid to reproduce a full color image. Since the image data can be divided into three sets, it is easier for a computer with limited storage, memory, or processing speed to handle.

### Color line sequence reading

The scanner scans the document in one pass of the carriage, reading green, red, and blue for every line. This yields a more accurate color separation and, because the color for each pixel can be determined as soon as it is scanned, the color correction function can be used.

### Color byte sequence reading

The scanner scans the document in one pass of the carriage, reading green, red, and blue for every byte.

### Monochrome reading (standard)

In this mode, the scanner scans the document in one pass, and scans the image in monochrome (black and white) format. With 8 bits per pixel selected for the data format, the image data produced can contain up to 256 shades of gray. In standard monochrome reading, the dropout color is determined by the scanner model.

□ Dropout colors (monochrome reading only)

The dropout color is the color that is treated as white, and is not read during the scanning operation. On a color scanner a dropout color can be chosen from among green, red, or blue. Dropout color can be used to avoid reading a certain color of the document. For example, corrections written in red on a draft can be erased by specifying the red dropout color.

The settings of 10<sub>H</sub>, 20<sub>H</sub>, and 30<sub>H</sub> should be used only to intentionally specify a dropout color. To change from color scanning to monochrome without choosing a dropout color, use the value 00<sub>H</sub>.

When a dropout color is selected, the color attributes in the status byte indicate the selected primary color. The image data of a dropout color can also be used as the color image data of one of the separated colors.

**ESC D****Set data format****Format:**

B1 B2 B3 B4 B5 A5

Command: ASCII:           **ESC D**

Decimal:           27    68

Hexadecimal:   1B    44

Parameter:            i

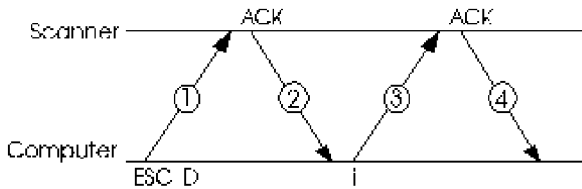
**Handshaking:**

- 1 **ESC D** command
- 2 **ACK** code
- 3 Parameter (i)
- 4 **ACK** code

**Parameter range:**i = 01<sub>H</sub> to 08<sub>H</sub> (1 to 8 bit/pixel/color)Default value: i = 01<sub>H</sub> (1 bit/pixel/color)**Explanation:**

This command specifies the number of bits that represent a pixel as the data format, in a range from 1 to 8 bits per pixel per color. As the value increases, more differences in tone and color can be represented.

In the color scanning mode, the data format setting defines tones for each of the three primary colors, green, red, and blue.

Data format	Monochrome	Color
1 bit/pixel/color	2 grays	8 colors
2 bit/pixel/color	4 grays	64 colors
3 bit/pixel/color	8 grays	512 colors
4 bit/pixel/color	16 grays	4,096 colors
5 bit/pixel/color	32 grays	32,768 colors
6 bit/pixel/color	64 grays	262,144 colors
7 bit/pixel/color	128 grays	2,097,152 colors
8 bit/pixel/color	256 grays	16,777,216 colors

Specifying the data format determines the amount of image data in each data block.

**Note:**

*Even when the specified values exceed the capabilities of the computer display or printer, data is sent according to the specified format and quantity. Before scanning, you should consider how the image data can be stored or processed.*

### **ESC D and other commands**

The data format selected by this command determines the effective halftoning mode selectable with the **ESC B** command.

With multilevel data settings (more than 3 bits per pixel per color) the halftoning modes are not effective.

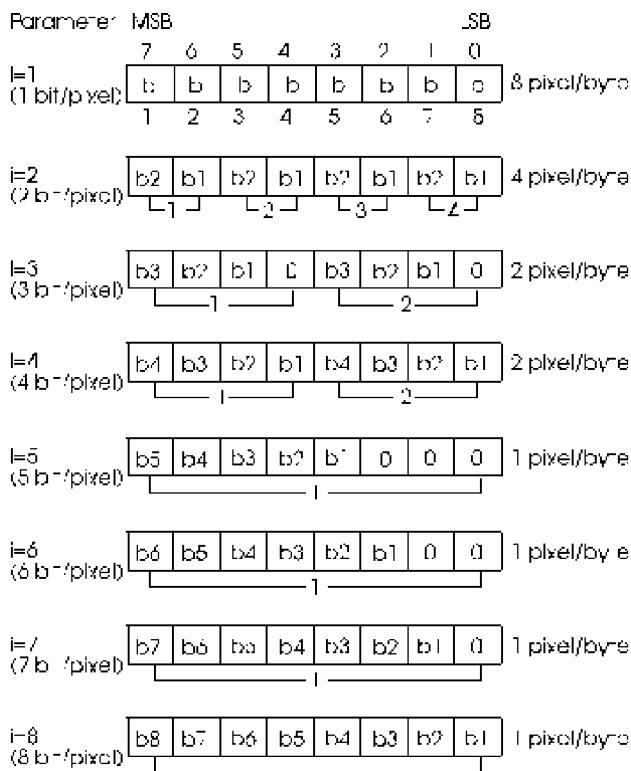

- Upper bits beginning with the MSB are valid. Lower bits not in use are fixed to 0.

## ESC R

## Set resolution

Format:

B1 B2 B3 B4 B5 A5

Command: ASCII:

ESC R

Decimal:

27

82

Hexadecimal:

1B

52

Parameter:

n1L

n1H

n2L

n2H

### Handshaking:

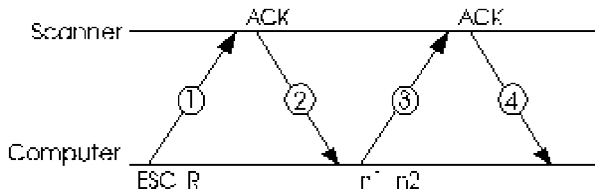

- 1 **ESC R** command
- 2 **ACK** code
- 3 Parameter (n1, n2)
- 4 **ACK** code

### Parameter range:

n1L, n1H = main scan resolution  
(lower byte, higher byte)  
n2L, n2H = sub scan resolution  
(lower byte, higher byte)

Default values: n1 = 100, n2 = 100 (in dpi)

**Explanation:**

This command sets the reading resolution of the main scan and sub scan.

n1 = Main scan resolution setting in dpi

n2 = Sub scan resolution setting in dpi

The settings available on each scanner model are listed in Appendix B.

The settings available can be checked with the identity data block that is obtained with the **ESC I** (Request identity) command.

If a value other than an available setting is received, a command error occurs, the command is ignored, and the current setting remains in effect.

**ESC R and other commands**

When this command is received, the scanning area is reset to the largest area possible with the currently selected resolution and zoom values. Because of this, set the scanning area with the **ESC A** command after the resolution (**ESC R**) and zoom (**ESC H**) settings have been made.

See Chapter 2 for details on software control procedures and on the use of the **ESC R**, **ESC H**, and **ESC A** commands. Also see the **ESC A** command.

**Note:**

*The parameters n1 and n2 are 2-byte values. The lower byte precedes the higher byte. When the scanner accepts this command, the scanning area is reset to the maximum value allowed with the current resolution and zoom settings. Always set the resolution and zoom before the scanning area is set.*



**Format:**

B2 B3 B4 B5 A5

Command: ASCII:	ESC	H
Decimal:	27	72
Hexadecimal:	1B	48
Parameter:	i1	i2

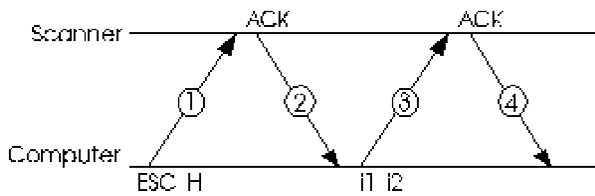
**Handshaking:**

- 1 **ESC H** command
- 2 **ACK** code
- 3 Parameter (i1, i2)
- 4 **ACK** code

**Parameter range:**

$$32_{\text{H}} (50) \leq i1 \leq \text{C}8_{\text{H}} (200)$$

$$32_{\text{H}} (50) \leq i2 \leq \text{C}8_{\text{H}} (200)$$

i1 = 50 to 200 (Main scan zoom, in %)

i2 = 50 to 200 (Sub scan zoom, in %)

Default values: i1 = 64<sub>H</sub> (100), i2 = 64<sub>H</sub> (100)

**Explanation:**

This command specifies the zoom values for the main scan (i1) and the sub scan (i2) in the range of 50% to 200%. The zoom value increment is 1% or 10%, depending on the scanner model. See Appendix B for details.

When the zoom is set with the control panel, the zoom value of the main scan and sub scan are equal. The setting made with this command overrides the setting made from the control panel.

**ESC H and other commands**

When the scanner accepts this command, the scanning area is reset to the maximum value allowed with the current resolution and zoom settings. Always set the zoom before setting the scanning area.

See Chapter 2 for details on the software control procedures and on the use of the **ESC R**, **ESC H**, and **ESC A** commands. Also see the **ESC A** command.

**ESC A****Set scanning area****Format:**

B1 B2 B3 B4 B5 A5

Command: ASCII:

ESC A

Decimal:

27

65

Hexadecimal:

1B

41

Parameters:

n1L, n1H, n2L, n2H, n3L, n3H, n4L, n4H

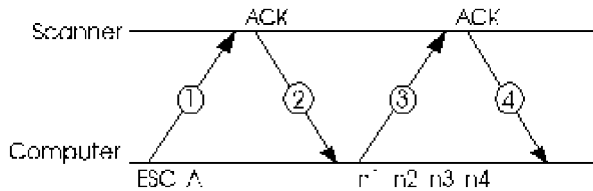
**Handshaking:**

- 1 **ESC A** command
- 2 **ACK** code
- 3 Parameter (n1, n2, n3, n4)
- 4 **ACK** code

**Parameter range:**

n1L, n1H = main scan offset length in dots

(lower byte, higher byte)

n2L, n2H = sub scan offset length in dots

(lower byte, higher byte)

n3L, n3H = main scan reading length in dots

(lower byte, higher byte)

n4L, n4H = sub scan reading length in dots

(lower byte, higher byte)

(See the **Explanation** section for details on the parameter range.)

Default value: Varies according to scanner model. See Appendix B for details.

**Explanation:**

This command specifies the scanning area as a rectangle measured from the origin, with lengths for the main scan and sub scan. The setting is made in units of dots (pixels).

The maximum values are determined by the current resolution (**ESC R**) and zoom (**ESC H**) settings. The values available for the scanning area depend on the scanner model, and can be calculated using the maximum scannable area and the maximum resolution values obtained with the **ESC I** command.

The values for parameters denote:

- n1: main scan offset length (2 bytes)
- n2: sub scan offset length (2 bytes)
- n3: main scan reading length (2 bytes)
- n4: sub scan reading length (2 bytes)

**Offset lengths and scanning length**

The offset lengths determine the offsets of the starting point of the specified scanning area, as measured from the origin. When these values are 0, the scanning area starting point is the origin. When they are specified as 10 dots each, the scanning area starts from dot 11 for the main scan and sub scan.

The scanning length determines the length and width of the scanning area, starting from the origin or from the offset position.

The offset and scanning lengths (n1 to n4) should be integer values within the available range of the main scan length and sub scan length. The maximum main scan and sub scan lengths are determined by the current resolution and zoom settings, and the parameter range for the **ESC A** parameter falls within the values shown below.

$$0 \leq n1 \leq (\text{maximum main scan length}) - 8$$

$$0 \leq n2 \leq (\text{maximum sub scan length}) - 1$$

$$8 \leq n3 \leq (\text{maximum main scan length}) - n1$$

$$1 \leq n4 \leq (\text{maximum sub scan length}) - n2$$

The sum of the offset length and scanning length, either for the main scan and sub scan, should not exceed the maximum length determined by the resolution and zoom settings.

**Caution:**

**C** *The length of the main scan should always be specified in units of 8 dots, or an integer multiple of 8. Otherwise, a comm and error occurs in the scanner.*

### Calculation of the maximum reading area

When the resolution is R dpi and the zoom is H%, the values for the maximum reading area are obtained with the following calculation.

$$\text{Main scan} : 8 \times \text{INT} ((X_L/R_{\text{max}}) \times (R \times H/100)/8)$$

$$\text{Sub scan} : \text{INT} ((Y_L/R_{\text{max}}) \times (R \times H/100))$$

$X_L =$  The maximum main scan length obtained with the **ESC I** command (in dots)

$Y_L =$  The maximum sub scan length obtained with the **ESC I** command (in dots)

$R_{\text{max}} =$  The maximum resolution setting obtained with the **ESC I** command (in dpi)

**Note:**

*INT(X) is a function that returns the integer of the given value X.*

The physical distance of the offset lengths and scanning lengths depends on the current dpi and zoom settings. For example, when the main scan and sub scan lengths are set to 400 dots and 640 dots respectively (at 100 dpi and 100%), the physical lengths are 4 inches (10.16 cm) and 6.4 inches (16.26 cm) respectively.

### **Relation to other commands**

The reading area is reset to the maximum value when the **ESC R** (Set resolution) command or **ESC H** (Set zoom) command settings are made. Make those settings before the scanning area is specified.

The scanning length determines the number of pixels (dots) to be read. The actual image data can vary from 1 bit per pixel to 8 bits per pixel according to the data format setting made with the **ESC D** command.

The main scan value should always be specified as a number that is a multiple of 8. The offset lengths can be any integer value.

## Reading area

The figure below illustrates the scanning area definition.

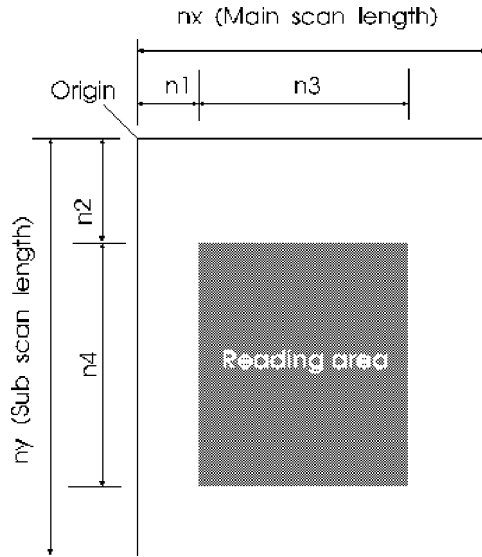

**C** **Caution:** *If the reading area parameters are wrong, a command error occurs in the scanner. The most likely mistake is that the value used for the main scan is not a multiple of 8. The maximum value of  $n_3$  is different for each scanner. The offset length can be set in units of one.*

**Format:**

B5 A5

Command: ASCII:           ESC   K  
                   Decimal:       27    75  
                   Hexadecimal: 1B    4B

Parameters:                    i

**Handshaking:**

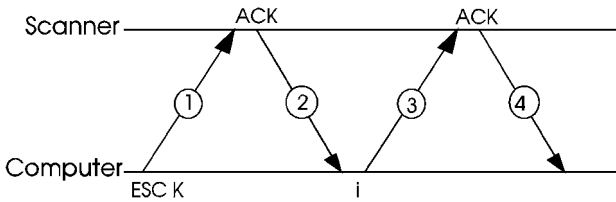

- 1 **ESC K** command
- 2 **ACK** code
- 3 Parameter (i)
- 4 **ACK** code

**Parameter range:**

i = 00H (0): Left top first (from left to right)  
 i = 01H (1): Right top first (from right to left)

Default values: i = 00H

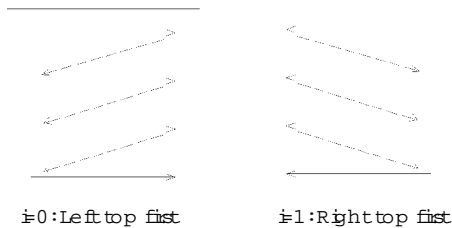



**Explanation:**

This command selects the order of image data.

The position of the origin is not affected by the order.

---

## Image Definition Commands

<b>ESC L</b>		<b>Set brightness</b>	
<b>Format:</b>		B2 B3 B4 B5 A5	
Command:	ASCII:	ESC	L
	Decimal:	27	76
	Hexadecimal:	1B	4C
Parameter:	i		

### Handshaking:

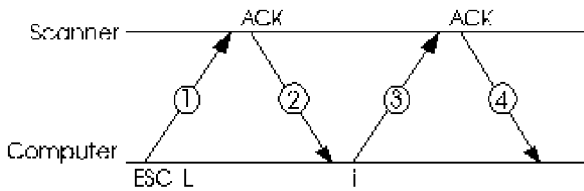

- 1 **ESC L** command
- 2 **ACK** code
- 3 Parameter (i)
- 4 **ACK** code

**Parameter range:**

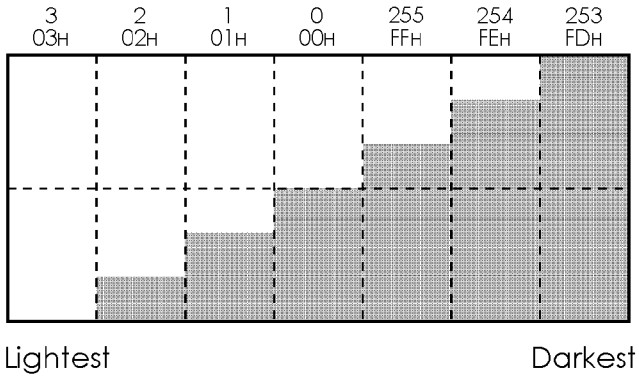

Default value:  $i = 00_H$  (center)

## Explanation:

This command sets the brightness level of the scanned image data. Seven values for *i* are available: 00<sub>H</sub>, 01<sub>H</sub>, 02<sub>H</sub>, 03<sub>H</sub>, FF<sub>H</sub>, FE<sub>H</sub>, and FD<sub>H</sub>.

The graph below shows the differences between the brightness settings when gamma correction is set for the CRT Display A setting.

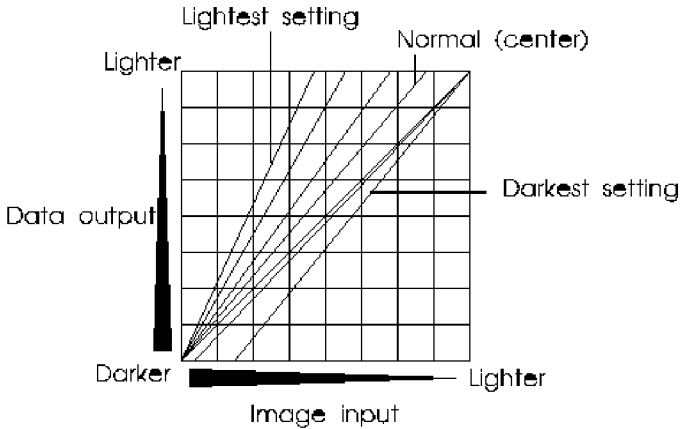

### **Note:**

*The brightness parameter is not available if a user-defined gamma correction table (see **ESC Z**) is selected.*

**ESC Z****Set gamma correction****Format:**

B2 B3 B4 B5 A5

Command: ASCII:           ESC   Z

Decimal:           27    90

Hexadecimal:   1B    5A

Parameter:           i

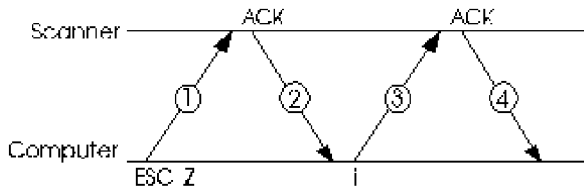
**Handshaking:**

- 1 **ESC Z** command
- 2 **ACK** code
- 3 Parameter (i)
- 4 **ACK** code

**Parameter range:**

- |                                        |                |
|----------------------------------------|----------------|
| i = 01H (1) : CRT Display A            | B2 B3 B4 B5 A5 |
| i = 02H (2) : CRT Display B            | B2 B3 B4 B5 A5 |
| i = 00H (0) : Printer Output A         | B2 B3 B4 B5 A5 |
| i = 03H (3) : User-defined Gamma Table | B4 B5 A5       |
| i = 10H (16) : Printer Output B        | B2 B3 B4 B5 A5 |
| i = 20H (32) : Printer Output C        | B2 B3 B4 B5 A5 |

Default value: i = 01H

## Explanation:

This command specifies the gamma correction setting for the output device.

The gamma correction refers to the gamma correction table stored in the scanner's internal memory, and adjusts the conversion ratio between the input intensity of the original image and the output image data values.

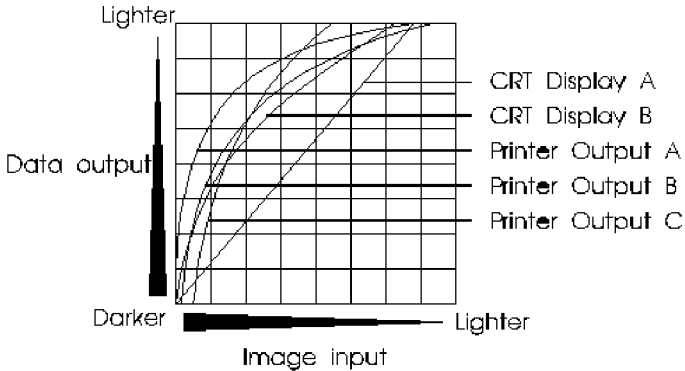

The various predefined mode settings have the following characteristics.

### **CRT Display A** (for bi-level data)

This setting is suitable for CRT display types that are incapable of displaying different tones of gray or colors. For example, this setting is suitable for displays that can produce only 8 or 16 colors.

### **CRT Display B** (for multilevel data)

This setting is suitable for high performance CRT displays that can display different tones of gray or colors. For example, this mode is suitable for displays that can show more than 16 colors.

**Printer Output A** (High density printers)

This setting is appropriate for printing on high density printers, such as 24-dot printers and laser printers. Since high density printing increases the darker components of the image, this setting compensates by producing data that is lighter than that used by a CRT display.

**Printer Output B** (Low density printers)

This mode is suitable for low density printing on 8 dot (9 pin) printers. This mode is similar to the Printer Output A mode, but the conversion curve is slightly different to compensate for the different printer characteristics. This mode is also suitable for printing on printers that produce finer dots, such as high-resolution laser printers and ink jet printers.

**Printer Output C** (High contrast, for mixed images and text)

This setting is suitable for images that require more clarity and distinction, such as mixtures of text and graphics. It is also suitable for printing on laser printers that can produce more distinct images than impact dot matrix printers. As shown in the graph above, this mode makes lighter parts as light as possible, and darker parts as dark as possible.

**Note:**

*The default gamma correction (CRT Display A) is used if 03H is specified for the i parameter without first downloading a user-defined gamma table (ESC z).*

**Format:**

B4 B5 A5

Command: ASCII: ESC z

Decimal: 27 122

Hexadecimal: 1B 7A

Parameter: i d (256 bytes)

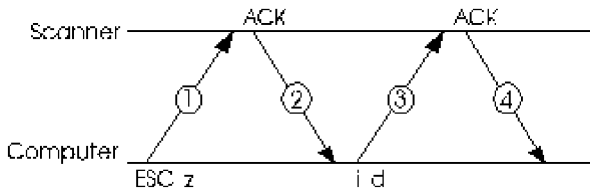
**Handshaking:**

- 1 **ESC z** command
- 2 **ACK** code
- 3 Parameters (i, d)
- 4 **ACK** code

**Parameter range:**

i = "m" or "M" : Monochrome  
 i = "r" or "R" : Red  
 i = "g" or "G" : Green  
 i = "b" or "B" : Blue

Default value: i = "m" or "M"



## Explanation:

This command downloads a user-defined gamma correction table to the scanner. This command is used when suitable gamma correction is not provided by any of the five gamma correction tables built into the scanner.

Specify “m” or “M” for the i parameter when defining a gamma correction table for monochrome scanning, or when setting the same gamma correction tables for all color component colors (red, green, and blue). When defining different gamma correction tables for each component color for color scanning, specify a value for i (“r” or “R”; “g” or “G”; “b” or “B”) that is appropriate for the applicable color.

### Note:

*The brightness command is ineffective when a gamma table defined with this command is selected by the **ESC Z** (Set gamma correction) command.*

*G a m m a t a b l e*

Index data	Output data
0	d0
1	d1
2	d2
3	d3
.	.
.	.
.	.
FF	d255

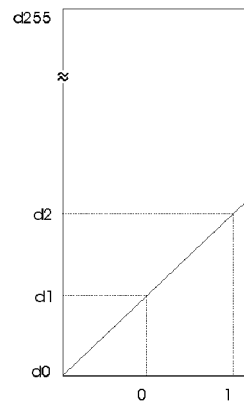

**Format:**

B4 B5 A5

Command: ASCII:           ESC    Q  
                   Decimal:       27    81  
                   Hexadecimal:  1B    51

Parameter:                    i

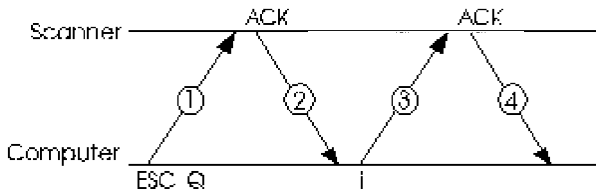
**Handshaking:**

- 1 **ESC Q** command
- 2 **ACK** code
- 3 Parameter (i)
- 4 **ACK** code

**Parameter range:**

i = FE<sub>H</sub> : More defocused  
 i = FF<sub>H</sub> : Defocused  
 i = 00<sub>H</sub> : Normal  
 i = 01<sub>H</sub> : Sharp  
 i = 01<sub>H</sub> : Sharper

Default value: i = 00<sub>H</sub>

**Explanation:**

This command selects from the five sharpness levels indicated above.

---

## Image Processing Commands

**ESC B**

**Set halftoning mode**

---

Format:

B1 B2 B3 B4 B5 A5

Command: ASCII:

**ESC B**

Decimal:

27

66

Hexadecimal:

1B

42

Parameter:

i

### Handshaking:

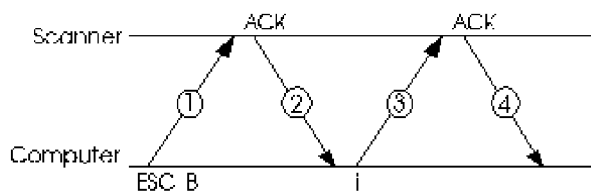

- 1 **ESC B** command
- 2 **ACK** code
- 3 Parameter (i)
- 4 **ACK** code

## Parameter range:

i= 00<sub>H</sub> (0): Enable halftoning mode A (hard tone): B1 B2 B3 B4 B5 A5  
i= 10<sub>H</sub> (16): Enable halftoning mode B (soft tone): B2 B3 B4 B5 A5  
i= 20<sub>H</sub> (32): Enable halftoning mode C (net-screen): B2 B3 B4 B5  
i= 80<sub>H</sub> (128): Dither mode A (4 x 4 Bayer): B4 B5 A5  
i= 90<sub>H</sub> (144): Dither mode B (4 x 4 spiral): B4 B5 A5  
i= A0<sub>H</sub> (160): Dither mode C (4 x 4 net screen): B4 B5 A5  
i= B0<sub>H</sub> (176): Dither mode D (8 x 4 net screen): B4 B5 A5  
i= C0<sub>H</sub> (192): User-defined dither pattern A: B4 B5 A5  
i= D0<sub>H</sub> (208): User-defined dither pattern B: B4 B5 A5  
i= 01<sub>H</sub> (1): Disable the halftoning process, Disable Text            Enhancement  
Technology: B1 B2 B3 B4 B5 A5  
i= 03<sub>H</sub> (3): Disable the halftoning process, Enable Text            Enhancement  
Technology: B5 A5

Default value: i = 00<sub>H</sub>

## Explanation:

This command enables or disables the halftoning process modes for bi-level (1 bit per pixel per color) and quad-level (2 bits per pixel per color) data.

This command also enables or disables Text Enhancement Technology, which optimizes the threshold value and eliminates background noises.

During halftoning mode, the level (on or off) and color of newly read pixels is determined in conjunction with the calculated level and color of surrounding dots that have already been read. This method is designed to interpolate for possible errors during the process of digitizing the image data. In contrast, the dither modes use fixed patterns in a matrix to simulate tonal values.

When the halftoning mode is disabled, the image data becomes plain bi-level or plain quad-level data, according to the data format.

The halftoning process simulates tone differences in an image with bi-level or quad-level data. It is suited for scanning originals with continuous tones, such as photographs. This process is not suited for images without varying tones, such as line art.

Each halftoning mode has the following characteristics.

**Halftoning mode A** (hard tone)

The image is processed to produce hard tones, to express distinction. This mode is suitable for most purposes.

**Halftoning mode B** (soft tone)

The image is processed to give soft tones. This mode is suitable for images that contain large areas of similar tones.

### Halftoning mode C (net-screen)

The image is processed so that it is represented similar to the net screen used in newspaper printing. The gradations of the tones are represented by clusters of different numbers of dots.

### Dither modes A, B, C, and D (fixed pattern dithering)

These modes have the following dither patterns.

	Dither mode A 4x4 Bayer	Dither mode B 4x4 Spiral	Dither mode C 4x4 Net screen																																																
Dither pattern	<table border="1"><tr><td>15</td><td>7</td><td>13</td><td>5</td></tr><tr><td>3</td><td>11</td><td>1</td><td>9</td></tr><tr><td>12</td><td>4</td><td>14</td><td>6</td></tr><tr><td>0</td><td>11</td><td>2</td><td>10</td></tr></table>	15	7	13	5	3	11	1	9	12	4	14	6	0	11	2	10	<table border="1"><tr><td>2</td><td>9</td><td>8</td><td>1</td></tr><tr><td>10</td><td>15</td><td>14</td><td>7</td></tr><tr><td>11</td><td>12</td><td>13</td><td>6</td></tr><tr><td>3</td><td>4</td><td>5</td><td>0</td></tr></table>	2	9	8	1	10	15	14	7	11	12	13	6	3	4	5	0	<table border="1"><tr><td>1</td><td>2</td><td>9</td><td>6</td></tr><tr><td>3</td><td>15</td><td>14</td><td>8</td></tr><tr><td>10</td><td>12</td><td>13</td><td>5</td></tr><tr><td>7</td><td>11</td><td>4</td><td>0</td></tr></table>	1	2	9	6	3	15	14	8	10	12	13	5	7	11	4	0
15	7	13	5																																																
3	11	1	9																																																
12	4	14	6																																																
0	11	2	10																																																
2	9	8	1																																																
10	15	14	7																																																
11	12	13	6																																																
3	4	5	0																																																
1	2	9	6																																																
3	15	14	8																																																
10	12	13	5																																																
7	11	4	0																																																
Threshold value	<table border="1"><tr><td>248</td><td>120</td><td>216</td><td>88</td></tr><tr><td>56</td><td>184</td><td>24</td><td>152</td></tr><tr><td>200</td><td>72</td><td>232</td><td>104</td></tr><tr><td>8</td><td>136</td><td>40</td><td>168</td></tr></table>	248	120	216	88	56	184	24	152	200	72	232	104	8	136	40	168	<table border="1"><tr><td>40</td><td>152</td><td>136</td><td>24</td></tr><tr><td>168</td><td>248</td><td>232</td><td>120</td></tr><tr><td>184</td><td>200</td><td>216</td><td>104</td></tr><tr><td>56</td><td>72</td><td>88</td><td>8</td></tr></table>	40	152	136	24	168	248	232	120	184	200	216	104	56	72	88	8	<table border="1"><tr><td>24</td><td>40</td><td>152</td><td>104</td></tr><tr><td>56</td><td>248</td><td>232</td><td>136</td></tr><tr><td>168</td><td>200</td><td>216</td><td>88</td></tr><tr><td>120</td><td>184</td><td>72</td><td>8</td></tr></table>	24	40	152	104	56	248	232	136	168	200	216	88	120	184	72	8
248	120	216	88																																																
56	184	24	152																																																
200	72	232	104																																																
8	136	40	168																																																
40	152	136	24																																																
168	248	232	120																																																
184	200	216	104																																																
56	72	88	8																																																
24	40	152	104																																																
56	248	232	136																																																
168	200	216	88																																																
120	184	72	8																																																

Dither mode D 8x4 Net screen																																																																																																																																		
<table border="1"><tr><td>29</td><td>23</td><td>6</td><td>0</td><td>8</td><td>12</td><td>20</td><td>28</td></tr><tr><td>22</td><td>5</td><td>1</td><td>17</td><td>16</td><td>11</td><td>13</td><td>21</td></tr><tr><td>4</td><td>2</td><td>18</td><td>26</td><td>25</td><td>15</td><td>10</td><td>9</td></tr><tr><td>3</td><td>19</td><td>27</td><td>31</td><td>30</td><td>24</td><td>14</td><td>7</td></tr><tr><td>8</td><td>12</td><td>20</td><td>28</td><td>29</td><td>23</td><td>6</td><td>0</td></tr><tr><td>16</td><td>11</td><td>13</td><td>21</td><td>22</td><td>5</td><td>1</td><td>17</td></tr><tr><td>25</td><td>15</td><td>10</td><td>9</td><td>4</td><td>2</td><td>18</td><td>26</td></tr><tr><td>30</td><td>24</td><td>14</td><td>7</td><td>3</td><td>19</td><td>27</td><td>31</td></tr></table>	29	23	6	0	8	12	20	28	22	5	1	17	16	11	13	21	4	2	18	26	25	15	10	9	3	19	27	31	30	24	14	7	8	12	20	28	29	23	6	0	16	11	13	21	22	5	1	17	25	15	10	9	4	2	18	26	30	24	14	7	3	19	27	31	<table border="1"><tr><td>236</td><td>188</td><td>52</td><td>4</td><td>68</td><td>100</td><td>164</td><td>228</td></tr><tr><td>180</td><td>44</td><td>12</td><td>140</td><td>132</td><td>92</td><td>108</td><td>172</td></tr><tr><td>36</td><td>20</td><td>148</td><td>212</td><td>204</td><td>124</td><td>84</td><td>76</td></tr><tr><td>28</td><td>156</td><td>220</td><td>252</td><td>244</td><td>196</td><td>116</td><td>60</td></tr><tr><td>68</td><td>100</td><td>164</td><td>228</td><td>236</td><td>188</td><td>52</td><td>4</td></tr><tr><td>132</td><td>92</td><td>108</td><td>172</td><td>180</td><td>44</td><td>12</td><td>140</td></tr><tr><td>204</td><td>124</td><td>84</td><td>76</td><td>36</td><td>20</td><td>148</td><td>212</td></tr><tr><td>244</td><td>196</td><td>116</td><td>60</td><td>28</td><td>156</td><td>220</td><td>252</td></tr></table>	236	188	52	4	68	100	164	228	180	44	12	140	132	92	108	172	36	20	148	212	204	124	84	76	28	156	220	252	244	196	116	60	68	100	164	228	236	188	52	4	132	92	108	172	180	44	12	140	204	124	84	76	36	20	148	212	244	196	116	60	28	156	220	252	Dither pattern
29	23	6	0	8	12	20	28																																																																																																																											
22	5	1	17	16	11	13	21																																																																																																																											
4	2	18	26	25	15	10	9																																																																																																																											
3	19	27	31	30	24	14	7																																																																																																																											
8	12	20	28	29	23	6	0																																																																																																																											
16	11	13	21	22	5	1	17																																																																																																																											
25	15	10	9	4	2	18	26																																																																																																																											
30	24	14	7	3	19	27	31																																																																																																																											
236	188	52	4	68	100	164	228																																																																																																																											
180	44	12	140	132	92	108	172																																																																																																																											
36	20	148	212	204	124	84	76																																																																																																																											
28	156	220	252	244	196	116	60																																																																																																																											
68	100	164	228	236	188	52	4																																																																																																																											
132	92	108	172	180	44	12	140																																																																																																																											
204	124	84	76	36	20	148	212																																																																																																																											
244	196	116	60	28	156	220	252																																																																																																																											
		Threshold value																																																																																																																																

## **ESC B and other commands**

This command is not available if a value other than 01<sub>H</sub> (1 bit per pixel per color) and 02<sub>H</sub> (2 bits per pixel per color) is specified with the **ESC D** (Set data format) command.

If a user-defined dither pattern is specified when none has been downloaded, the Dither mode A is selected.

The parameter 03<sub>H</sub> is effective only when **ESC D** 01<sub>H</sub> is specified.

Text Enhancement Technology is available only when or monochrome reading is specified with **ESC C**.

**Format:**

B4 B5 A5

Command:	ASCII:	<b>ESC</b>	<b>b</b>
	Decimal:	27	98
	Hexadecimal:	1B	62

Parameter:	i	j	$d(j^2)$
------------	---	---	----------

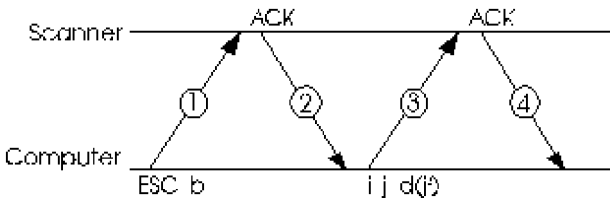
**Handshaking:**

- 1 **ESC b** command
- 2 **ACK** code
- 3 Parameter i j
- 4 Parameter d ( $j^2$ )
- 5 **ACK** code

**Parameter range:**

i = 00H	: User pattern A	
i = 01H	: User pattern B	
j = 04H	: 4 x 4 matrix	d(16)
j = 08H	: 8 x 8 matrix	d(64)
j = 16H	: 16 x 16 matrix	d(256)
d	: Threshold value	
$0 \leq d \leq 255$		

Default value: No user definition



## Explanation:

This command sets the threshold values for user-defined dither patterns. The patterns defined with this command can be selected by the **ESC B** command.

Parameter *i* can be 0 or 1, allowing you to define two dither patterns.

Parameter *j* determines the number of pixels on one side of the dither matrix square. The square can be  $4 \times 4$ ,  $8 \times 8$ , or  $16 \times 16$  pixels.

Parameter *d* is data representing the threshold values of the pixel positions in the matrix. The number of bytes of threshold data is determined by parameter *j*, and should be  $j^2$  bytes. For example, when  $j = 4$ , the threshold data required is 16 bytes ; and when  $j = 8$ , the threshold data required is 64 bytes.

The threshold data assigns threshold values to pixel positions in the matrix from top left to bottom right, as shown below. Since the value of the input image data can range from 0 (dark) to 255 (bright), each byte of threshold data can take a value ranging from 0 to 255.

An example of a  $4 \times 4$  spiral pattern is shown below.

13	6	7	14
5	0	1	8
4	3	2	9
12	11	10	15

4x4 spiral  
dither pattern

216	104	120	232
88	8	24	136
72	56	40	152
200	184	168	248

Threshold value

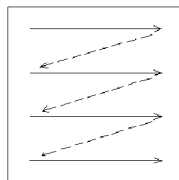

**Format:**

B3 B4 B5

Command:	ASCII:	ESC	M
	Decimal:	27	77
	Hexadecimal:	1B	4D

Parameter:                    i

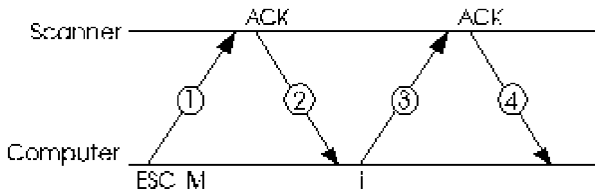
**Handshaking:**

- 1 **ESC M** command
- 2 **ACK** code
- 3 Parameter (i)
- 4 **ACK** code

**Parameter range:**

- i = 10H (0) : For color impact dot matrix printers
- i = 01H (1) : User defined value
- i = 20H (32) : For color thermal transfer printers
- i = 40H (64) : For color ink jet printers
- i = 80H (128) : For color CRT displays

Default value: i = 80H

**Explanation:**

This command specifies the color correction to suit the selected type of color output device.

This command is valid only when color line sequence reading or byte sequence is specified by the **ESC C** (Set color) command.

The parameter  $01_{\text{H}}$  setting is effective only after downloading color correction with **ESC m**.

**ESC m****Download color correction****Format:**

B4 B5

Command:            ASCII:            **ESC m**  
                      Decimal:            27      109  
                      Hexadecimal:    1B      60

Parameter:                            d1, d2, d3, d4, d5, d6, d7, d8, d9

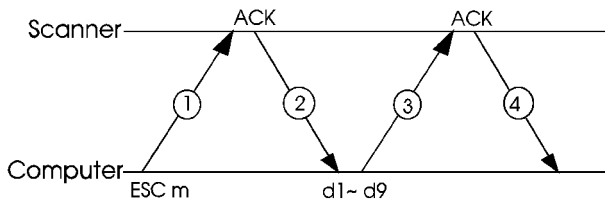
**Handshaking:**

- 1 **ESC m** command
- 2 **ACK** code
- 3 Parameter (d1 ~ d9)
- 4 **ACK** code

**Parameter range:**

$$-127 \leq d1, d2, d3, d4, d5, d6, d7, d8, d9 \leq 127$$

Each data is a signed byte, and the data format is as follows.

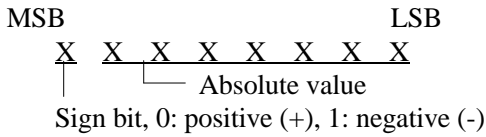
**Explanation:**

This command downloads 9 coefficient data bits for color correction.

A scanner converts color data according to the following formula.

$$\begin{vmatrix} G' \\ R' \\ B' \end{vmatrix} = \frac{1}{32} \times \begin{vmatrix} d1 & d4 & d7 \\ d2 & d5 & d8 \\ d3 & d6 & d9 \end{vmatrix} \times \begin{vmatrix} G \\ R \\ B \end{vmatrix}$$

G', R', B' : Converted data for color correction

G, R, B : Original data

d1, d2, d3, d4, d5, d6, d7, d8, d9: Coefficient values

**Format:**

A5

Command:	ASCII:	ESC	s
	Decimal:	27	115
	Hexadecimal:	1B	73

Parameter: i

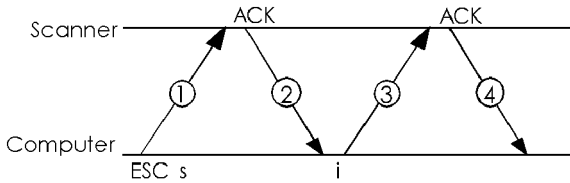
**Handshaking:**

- 1 **ESC s** command
- 2 **ACK** code
- 3 Parameter (i)
- 4 **ACK** code

**Parameter range:**

- i = 00H: Disable auto area segmentation
- i = 01H: Enable auto area segmentation  
(Text area = TET OFF, Photo area = [ESC B])
- i = 02H: Enable auto area segmentation  
(Text area = TET ON, Photo area = [ESC B])

**Note:**

*TET (Text Enhancement Technology [ESC B]) is available when the data format is set to 1 bit/pixel.*

**Explanation:**

The Text area and Photo area are segmented and processed separately according to the selected parameters.

---

## Auxiliary Commands

<b>ESC @</b>		<b>Initialize the scanner</b>	
<b>Format:</b>			B2 B3 B4 B5 A5
Command:	ASCII:	<b>ESC @</b>	
	Decimal:	27	64
	Hexadecimal:	1B	40
Parameter:		(none)	

### Handshaking:

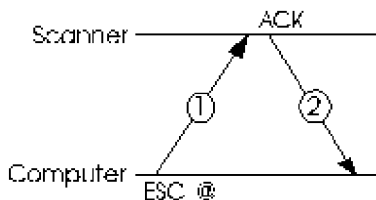

- 1 **ESC @** command
- 2 **ACK** code

### Explanation:

When this command is received, the scanner initializes itself, and the command settings are reset to the default values. Downloaded data, such as user-defined dither patterns, remains.

**ESC d****Set line counter****Format:**

B4 B5 A5

Command:	ASCII:	<b>ESC</b>	<b>d</b>
	Decimal:	27	100
	Hexadecimal:	1B	64

Parameter:                    i

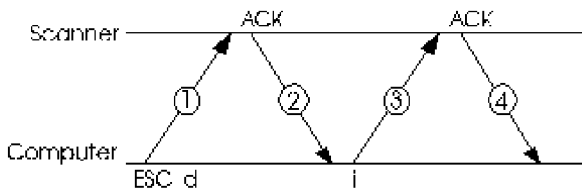
**Handshaking:**

- 1 **ESC d** command
- 2 **ACK** code
- 3 Parameter **i**
- 4 **ACK** code

**Parameter range:**

$$0 \leq i \leq 255$$

**Explanation:**

This command sets the number of the line counter for use with block-structure data blocks. This makes it possible for the scanner to send multiple lines of image data in one data block.

The line counter setting is canceled upon execution of the **ESC G** (Start scanning) command. In other words, the scanner returns to line-structure data transmission following execution of **ESC G**.



Parameter *i* determines the number of image lines that are included in the data block. The value specified must be greater than 0 and less than or equal to 255. (If 0 is specified, the scanner returns **NAK** in response to this command.)

When the block data transfer mode is enabled with this command, the receiving host computer must check the line counter and byte counter in the data block to ensure the image data is received correctly. If the color line sequence mode is selected, the host computer should count the number of image data lines separately for green, red, and blue data.

Note that since the number of sub scan lines can vary, the value of the line counter for the last data block will usually not be the same as *i*. Therefore, the line counter must be checked in order to ensure correct image data reception. For a given sub scan read length (SSRL), the number of lines in the last data block can be determined as follows.

MOD (SSRL/*i*)

**Note:**

- ❑ *MOD* is a function that produces the remainder of a division operation.
- ❑ The **ESC d** command is effective for increasing scanning speed, especially when using the SCSI interface.

**Format:**

B4 B5 A5

Command:	ASCII:	<b>ESC</b>	<b>g</b>
	Decimal:	27	103
	Hexadecimal:	1B	67

Parameter:                    i

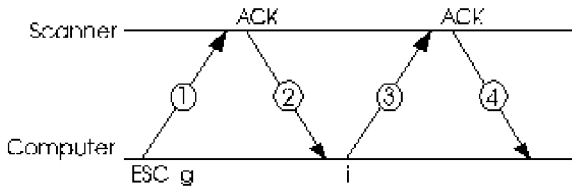
**Handshaking:**

- 1 **ESC g** command
- 2 **ACK** code
- 3 Parameter **i**
- 4 **ACK** code

**Parameter range:**

i = 00H : Normal mode  
i = 01H : High speed mode

Default value: 00H

**Explanation:**

This command selects scanning in the high-speed mode or the normal mode. When the high-speed mode is selected, the carriage moves at about twice the speed of the normal mode.

The high-speed mode is suitable when scanning bi-level originals, such as text and line art. When scanning continuous tone images, as with 8-bit monochrome and 24-bit color scanning, use the normal mode.

**Note:**

- ❑ *To obtain the full benefit of high-speed data transfer, use the high speed scanning mode in combination with block-structure data lock transfer.*
- ❑ *The actual effectiveness of high speed scanning may be limited by host computer conditions, such as processing speed.*

**Format:**

EXT\*

Command:	ASCII:	<b>ESC</b>	<b>e</b>
	Decimal:	27	101
	Hexadecimal:	1B	65

Parameter: i

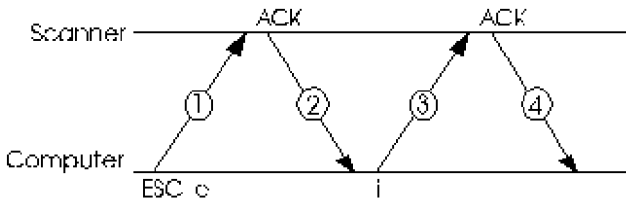
**Handshaking:**

- 1 **ESC e** command
- 2 **ACK** code
- 3 Parameter **i**
- 4 **ACK** code

**Parameter range:**

**i** = 01H : Enable option

**i** = 00H : Disable option

Default value: 00H

**Explanation:**

This command enables or disables the option.

Upon execution of this command, the **ESC C** (Set color) command is reset to the default value (**i**=00H: Standard monochrome). The color page sequence mode is not effective when the optional Automatic Document Feeder is installed. To scan in color, be sure to set the color line sequence or byte sequence mode with the **ESC C** command.



**Format:**

EXT

Command:            ASCII:            **FF**  
                          Decimal:            12  
                          Hexadecimal:    0C

Parameter:                    (none)

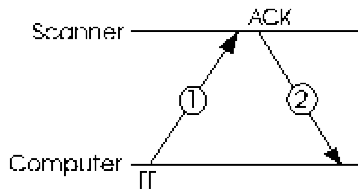
**Handshaking:**

- 1 **FF** code
- 2 Data block

**Explanation:**

Upon receiving this command, the scanner ejects the document currently loaded in the Automatic Document Feeder.

---

## **Control Codes**

The following four codes are used to control handshaking and data transfer between the computer and scanner.

<b>STX</b>	<b>Header</b>
------------	---------------

---

**Format:**

ASCII:        **STX**

Decimal:      2

Hexadecimal: 02

**Explanation:**

This code is used by the scanner and indicates the beginning of a data block.

**Format:**

ASCII:	CAN
Decimal:	24
Hexadecimal:	18

**Explanation:**

This code aborts a scanning operation, and returns the scanner to the command waiting mode (ready state). An **ACK** code is returned from the scanner.

This code should be sent by the computer in place of an **ACK** code during scanning operation. See the explanation of the **ESC G** command for more details.

The **CAN** code is valid only when the scanner is waiting for an **ACK** code during a scanning operation. If a **CAN** code is received at any other time, it is treated as a command error and a **NAK** code is returned from the scanner.



**ACK****Normal response (acknowledge)**

---

**Format:**

B1 B2 B3 B4 B5 A5

ASCII:        **ACK**

Decimal:      6

Hexadecimal: 06

**Explanation:**

This code is used by both the scanner and computer for handshaking. This code indicates that a command, a set of parameters, or a data block was legal and accepted by the receiving device.

The computer should always send an **ACK** code in response to a data block sent from the scanner, except after the last data block of a page of image data. If the computer fails to send an **ACK** code within 30 seconds, an interface error occurs in the scanner.

**Note:**

*The **ACK** code shown here is the ASCII code for 06<sub>H</sub>. The **ACK** code does not refer to the ACKNLG signal line of the interface.*

**NAK****Abnormal response (negative acknowledge)**

---

**Format:**

B1 B2 B3 B4 B5 A5

ASCII:        **NAK**

Decimal:      21

Hexadecimal: 15

**Explanation:**

This code is used by the scanner for handshaking. This code indicates that a command or a parameter was illegal and not accepted by the scanner.

When the **NAK** code is returned from the scanner, it means a command error has occurred in the scanner, and the command was ignored. To recover from a command error, resend a legal command or a command followed by a legal parameter.



---

## **Serial Interface Specifications**

Interface type:	RS-232C(D) compatible
Transfer method:	Asynchronous
Transfer speed:	Scanner model dependent
Data format:	Scanner model dependent
Handshaking:	ACK/NAK codes software handshaking
Signal voltage:	Logic "1", MARK = -3V to -27V Logic "0", SPACE = 3V to 27V
Connector type:	DB-25 (D-sub 25-pin). DB-295A-J4 (JAE)
Connector pin arrangement:	

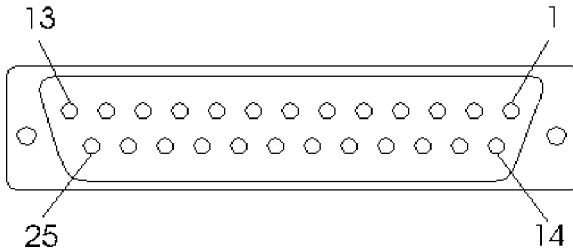

## Signal pin assignments

In this table, the direction of the signals is given relative to the scanner.

Pin No.	Signal	I/O	Description
1	C.GND	-	Chassis ground
2	TXD	Out	Transmit data
3	RXD	In	Receive data
4	RTS	Out	Request to send
5	CTS	In	Clear to send
6	DSR	In	Data set ready
7	S.GND	-	Signal ground
8-19	NC	-	-
20	DTR	Out	Data terminal ready
21-25	NC	-	-

## Cable wiring

A typical example of cable wiring is shown below.

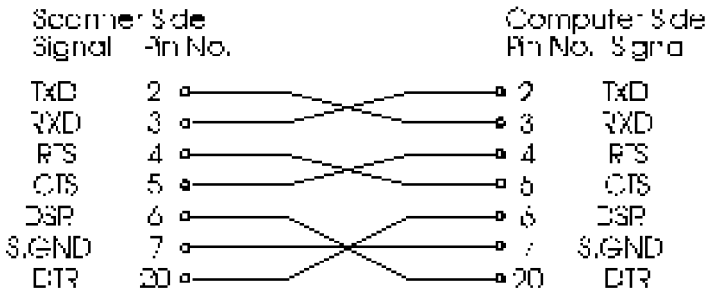

---

## ***Parallel Interface Specifications***

Interface type:	Bi-directional parallel interface
Data format:	8-bit parallel
Synchronization:	By external strobe pulse
Handshaking:	By ACKNLG and BUSY signals
Logic level:	Input/output data and interface control signals are TTL level compatible.
Connector type:	36-pin Centronics type connector
Connector pin arrangement:	

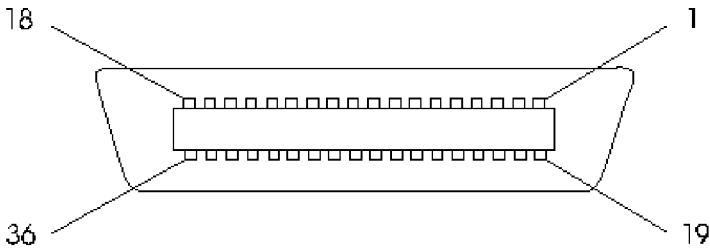

## Signal pin assignments

In this table, the direction of the signals is given relative to the scanner.

Pin No.	Return pin	Signal	I/O	Comment
1	19	$\overline{\text{STROBE}}$	IN	STROBE pulse to read in or send out data. Pulse width must be more than 0.5 microseconds at the receiving terminal.
2	20	DATA0	IN/OUT	These signals represent information of bits 1 to 8, respectively. Each signal is at a High level when data is logical 1 and Low when it is logical 0.
3	21	DATA1	IN/OUT	
4	22	DATA2	IN/OUT	
5	23	DATA3	IN/OUT	
6	24	DATA4	IN/OUT	
7	25	DATA5	IN/OUT	
8	26	DATA6	IN/OUT	
9	27	DATA7	IN/OUT	
10	28	$\overline{\text{ACKNLG}}$	OUT	About a 12-microsecond pulse. Low indicates that data has been received and that the scanner is ready to accept more data.
11	29	BUSY	OUT	When this signal is High, the scanner cannot receive data. The signal becomes High: 1) during data entry, 2) during scanning, 3) when the scanner is not ready, 4) when a scanner error occurs.
12–15	-	NC	-	Not used
16	-	GND	-	Logical ground level
17	-	C-GND	-	Scanner chassis ground

18	-	NC	-	Not used
19-30	-	NC	-	Twisted-pair return signal ground level
31	-	INIT	IN	When this signal level goes Low, the scanner is reset to its power-up state. This level is usually High. The pulse width must be more than 50 microseconds at the receiving terminal.
32	-	NC	-	Not used
33	-	GND	-	Twisted-pair return signal ground level
34-35	-	NC	-	Not used
36	-	DIR	IN	Low indicates the input direction

- ❑ “Return” denotes the twisted-pair return, to be connected at signal ground level. For interface wiring, be sure to use a twisted-pair cable for each signal, and to complete the connection on the return side. These cables should be shielded and connected to the chassis of the host computer and the scanner.
- ❑ All interface conditions are based on TTL level.



## Timing charts

The figures below show the timing for the bi-directional parallel interface.

OUT (Scanner to computer)

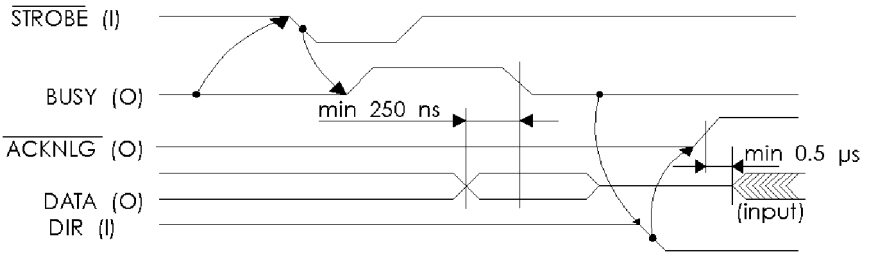

IN (Computer to scanner)

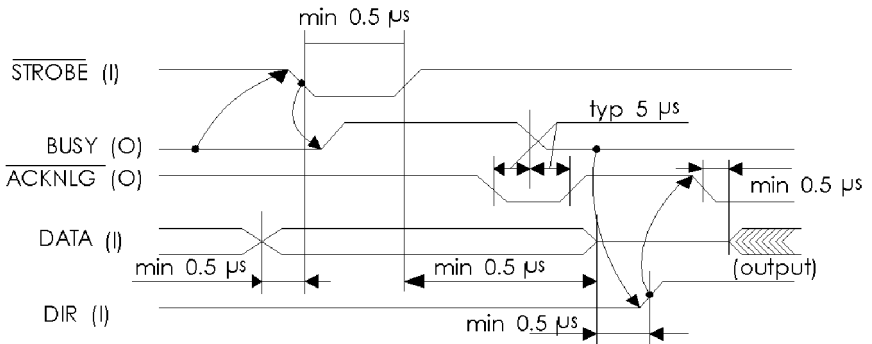

---

# **SCSI Interface Specifications**

## **Basic Specification**

Any item not included in this specification is in conformance with ANSI Standard X3.131-1986.

## **Functions**

The following functions covered by ANSI Standard X3.131-1986 are included.

- i) BUS FREE phase
- ii) ARBITRATION phase
- iii) RESELECTION phase
- iv) COMMAND phase

With this device, the LUN (Logical Unit Number) is fixed at 0. The command link function is not supported.

- v) DATA phase - DATA IN phase- DATA OUT phase
- vi) STATUS phase
- vii) MESSAGE phase- MESSAGE IN phase-MESSAGE OUT phase
- viii) ATTENTION condition
- ix) RESET condition

## **Logic Level**

TTL level compatible.

## **Electrical Specification**

Conforms to ANSI Standard X3.131-1986.

## **Terminator**

External or internal terminator.

## ***ID Switch Setting***

The SCSI ID is set with the ID switch mounted on the back of the scanner.

The ID switch numbers correspond to the available ID and can be set from 0 to 7. The numbers 8 and 9 should not be used.

## ***Command Chart***

This device uses the following group 0 processor commands.

Code	Command	Description
00H	TEST UNIT READY	Ready for operation confirmation
03H	REQUEST SENSE	Sense data request (*1)
08H	RECEIVE	Data transfer from target
0AH	SEND	Data transfer from initiator
12H	INQUIRY	SCSI device data request (*2)

\*1 For sense data returned by the REQUEST SENSE command, only the extension sense data format is supported.

\*2 The INQUIRY data returned by the INQUIRY command is as follows:

Peripheral device type : 03<sub>H</sub> (processor)  
: 00<sub>H</sub>  
RMB : 0<sub>B</sub>  
Device type qualifier : 00<sub>H</sub>  
: 00<sub>H</sub>  
ISO version : 0<sub>H</sub>  
ECMA version : 0<sub>H</sub>  
ANSI version : 0<sub>H</sub>  
Reserved : 00<sub>H</sub>  
Additional length : 23<sub>H</sub>  
Reserved : 00<sub>H</sub>, 00<sub>H</sub>, 00<sub>H</sub>  
Vendor unique parameter byte : "EPSON", 20<sub>H</sub>  
: "SCANNER", 20<sub>H</sub>,  
"\*\*\*\*\*",  
',  
20<sub>H</sub>, 20<sub>H</sub>, 20<sub>H</sub>, ff<sub>H</sub>  
: "EPSON", 20<sub>H</sub>, 20<sub>H</sub>, 20<sub>H</sub>  
: "SCANNER",  
"\*\*\*\*\*", 20<sub>H</sub>, ff<sub>H</sub>

**Note:**

"\*\*\*\*\*": Product name ex. "GT-8000", 20<sub>H</sub>, 20<sub>H</sub>, 20<sub>H</sub>, "1.00"

**Status List**

This device has the following status values:

7	6	5	4	3	2	1	0	STATUS
R	—	—	0	0	0	0	—	GOOD
R	—	—	0	0	0	1	—	CHECK CONDITION
R	—	—	0	1	0	0	—	BUSY
All other codes								Reserved

R: Reserved bit

## Message List

Code	Type	Message	Direction
00H	M	COMMAND COMPLETE	IN
01H-03H	O	Not Supported	
04H	O	DISCONNECT	IN
05H-06H	O	Not Supported	
07H	O	MESSAGE REJECT	IN    OUT
08H-0BH	O	Not Supported	
0CH	O	BUS DEVICE RESET	OUT
0DH-7FH	R	(Reserved)	
80H-FFH	O	IDENTIFY	IN    OUT

M: MANDATORY    O: OPTIONAL    R: Reserved  
 IN: Initiator ← Target    OUT: Target ← Initiator

## Connector pin arrangement

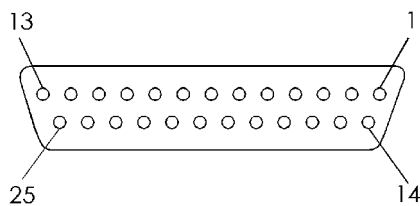
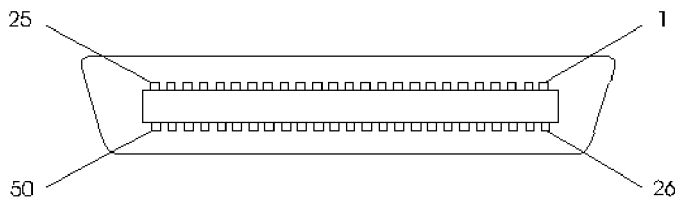

## Signal pin assignments

In this table, the direction of the signals is given relative to the scanner.

Signal	I/O	50 Pin No.	25 Pin No.	Description
GND		1–12 14–25 35–37 39–40 42	7–9 14 16 18 24	Ground
NC		13		Not connected
DB0	I/O	26	8	Data bus 0
DB1	I/O	27	21	Data bus 1
DB2	I/O	28	22	Data bus 2
DB3	I/O	29	10	Data bus 3
DB4	I/O	30	23	Data bus 4
DB5	I/O	31	11	Data bus 5
DB6	I/O	32	12	Data bus 6
DB7	I/O	33	13	Data bus 7
DBP	I/O	34	20	Data bus parity
TERMPWR		38	25	Termination power (+5V)
ATN	I	41	17	Attention
BSY	I/O	43	6	Busy
ACK	I	44	5	Acknowledge
RST	I	45	4	Reset
MSG	O	46	2	Message
SEL	I/O	47	19	Select
C/D	O	48	15	Control/Data
REQ	O	49	1	Request
I/O	O	50	3	Input/Output

---

## ***SCSI Operation Procedure***

This section explains the operational procedures for the SCSI. For details concerning SCSI specifications for individual operations, refer to ANSI X3.131-1986 "Small Computer System Interface."

### ***Communication Operation***

The following procedure is used to transfer data between the scanner (Target) and a host computer (Initiator).

- i The Target stands by in the Bus Free Phase until the Initiator selects it.
- ii When selected by the Initiator, the Target checks for ATN on the SCSI bus line. If active low (L), the Target changes to the Message Out Phase; the Initiator then sends a 1-byte message to the Target. The Target must receive the Identify message at this point. If the Target receives the Identify message or the Bus Device Reset message, the Target changes to the Message In Phase and sends the Message Reject message.
- iii When selected during a carriage reset, the scanner sends a BUSY status message and then advances to item x. When the scanner is in a fatal error state, it creates an error code and sense data and then advances to item ix.
- iv The Target changes to the Command Phase and receives a command (6-byte command of group 0). The target then checks the Link Flag bits in the command. If both are not '0', an error will occur, the Target creates an error code and sense data and then advances to item ix.
- v The Target checks the command. When the command operation code is Request Sense or Inquiry and there is no error in the other parameters, the command is executed. If there is a parameter error, however, the Target creates an error code and sense data and then advances to item ix.

- vi When the unit attention condition is set, the Target sends Check Condition status and then advances to item ix without executing the command.
- vii The Target rechecks the command operation code. If the command is Test Unit Ready, the command is executed. If there is a parameter error, however, the Target creates an error code and sense data and then advances to item ix. If the command operation code is not Send or Receive, the command is not supported by the scanner; the Target creates sense data and then advances to item ix.
- viii If the Target receives the Identify message in item ii, it checks the Disconnect bit of the message, sends the Disconnect message if necessary, and changes to the Bus Free Phase. After completing preparations for data send and receive, the Target checks to determine if the Bus Free Phase is in effect, performs Arbitration and Reselection, reconnects to the Initiator, changes to the Message In Phase, and sends the Identify message.

The Target checks the operation code of the command received in item iv. If there is no error in the parameters, the Target executes the Send and Receive commands. If there is a parameter error, however, the Target creates an error code and sense data.

- ix The Target changes to the Status Phase and checks for error codes. If an error is present, the Target sends Check Condition status; if there is no error, the Target sends Good status.
- x The Target changes to the Message In Phase and sends the Command Complete message; it then changes to the Bus Free Phase to complete the series of communications.



## **SCSI Commands**

The commands supported by EPSON scanners are explained below.

If the Link, Flag, and reserved bits of a command are a value other than 0, an error occurs and the command is not executed.

### 1. Test Unit Ready

If the scanner is ready for operation, Good status is sent; if an error occurs at this time, Check Condition status is sent.

### 2. Request Sense

The sense data in the scanner is sent when a request is received. Sense data is 8-byte data in the extension sense data format.

The number of sense data bytes sent is determined by specifying the assigned length. If more than 8 bytes are specified, 8 bytes of data are sent and then Data In Phase ends. If a length of 0 is specified, 4 bytes of sense data are sent. See *Sense Data* for details.

### 3. Inquiry

Device type data for the scanner is sent. There are 40 bytes of Inquiry data. Refer to SCSI specifications for a description of Inquiry data. The number of bytes of Inquiry data sent at this time is determined by specifying the assigned length. If more than 40 bytes are specified, 40 bytes of data are sent and then Data In Phase ends. If a length of 0 is specified, an error will not occur, but no data will be sent and the command will be terminated.

#### 4. Send, Receive

Data is sent to and received from the scanner. With this command, the transfer length and assigned length must be the same as the actual number of data bytes. For example, when the **ESC G** (Start reading) command is to be sent to the scanner, the transfer length must be 2 bytes; otherwise, an error occurs and the command is not executed. If the assigned length is 0, the command is ended.

### ***Unit Attention Condition***

When the power is turned on, or a reset is performed with the RESET condition or Bus Device Reset message, the scanner enters the Unit Attention condition. The Unit Attention condition then continues until a command other than Request Sense or Inquiry is received from the Initiator.

If a command other than Request Sense or Inquiry is received from an Initiator with a pending Unit Attention condition, the scanner sends the Check Condition status without executing the command. If the Request Sense command is received while in the Unit Attention condition, the scanner sends the Unit Attention sense data and clears the Unit Attention condition.

## Sense Data

The extension sense data format is used for the sense data created when an error occurs. This format is described below.

Byte	Bit	7	6	5	4	3	2	1	0
0		Valid	Error class (7)			Error code (0)			
1		Segment data number (0)							
2		File mark	EOM	ILI	Reserved	Sense keys			
3		Information byte (MSB)							
4		Information byte							
5		Information byte							
6		Information byte (LSB)							
7		Additional sense byte (0)							

Following is a description of the individual bits and bytes.

### **Valid:**

When set to 0, this bit indicates that the data in the data byte is invalid. When set to 1, the data is valid.

### **ILI:**

This is the illegal length bit. When set to 1, this bit indicates that the transfer length or assigned length specified with a command is not the same as the actual data length required by the scanner.

**Information byte:**

This byte has meaning only when the Valid bit is set to 0 and indicates the difference between the transfer length or assigned length specified with a command and the actual data length required by the scanner. The value entered here is calculated using the following formula.

$$\text{Information byte} = \text{transfer length} - \text{actual data length} \\ \text{(assigned length)}$$

(The data byte length is 0 when a negative value is specified.)

**Sense keys:**

The Initiator can determine the causes of scanner errors by monitoring the sense keys.

---

## ***Initialization***

The scanner is initialized (returned to a fixed set of conditions) in several ways.

### ***Hardware initialization***

- When the power is turned on
- When the RESET switch is pressed
- When the scanner receives an initializing signal in the interface

### ***Software initialization***

When the software command **ESC @** (Initialize the scanner) is received

### ***Default settings***

The default settings vary by model. See Appendix B for a list of default settings for all EPSON scanner models.

When the scanner is initialized, the scanner stops the current scanning operation, and the carriage returns to the home position (rear of the scanner).





---

## **GT-1000 Technical Data**

This appendix provides technical information that is relevant to software control of the EPSON GT-1000 color image scanner. For further details about this particular scanner model, see the GT-1000 user's guide.

### **Physical Characteristics**

Function level:	B2
Maximum reading area:	74mm × 105mm
Effective pixels:	592 × 840 dots at 200 dpi, 100%
Standard interface:	RS-232C serial Bi-directional parallel
Optional interface:	(not available)
Serial interface protocols:	
Transfer rate:	2400, 4800, 9600, and 19200 bps
Stop bit:	2 bits and 1 bit
Parity check:	None

### **Error Indications**

Scanner errors are displayed on the control panel by a combination of the ERROR and READY lights as shown below.

Error name	ERROR light	READY light
Command Error	On	On
Interface Error	Flashes	Off
Fatal Error	Flashes	Flashes



## Software Functions and Settings

The function level of the GT-1000 is B2. The table below lists the functions and settings that can be controlled with software commands.

Function	Available settings
Output resolution	3 settings (50, 100, 200 dpi)
Zoom	50% to 200% in 10% increments
Reading area	592 × 840 dots at 200 dpi, 100%
Data format	1 to 8 bits per pixel per color
Color mode	color (page sequence), monochrome (standard and with dropout color)
Brightness	7 levels
Halftoning mode	3 modes
Gamma correction	5 settings

## Software Defaults

With the DIP switches at the preset factory settings, the following values are the default values on the GT-1000 when the power is turned on.

Function	Command	Default value
Data format	ESC D	i=01 <sub>H</sub> (1 bit/pixel/color)
Resolution	ESC R	n1=100, n2=100 (dpi)
Zoom	ESC H	i1=100, i2=100 (%)
Reading area	ESC A	n1=0, n2=0, n3=296, n4=420 (dot)
Color mode	ESC C	i=00 <sub>H</sub> (monochrome)
Brightness	ESC L	BRIGHTNESS dial setting
Gamma correction	ESC Z	i=01 <sub>H</sub> (CRT Display A)
Halftoning mode	ESC B	i=00 <sub>H</sub> (Halftoning Mode A)

# DIP Switch Setting

The GT-1000 has one bank of DIP switches on the control panel. The tables below show the function of each switch and the preset factory settings. The shaded boxes show the factory settings.

Switch No.	Function	ON	OFF
SW 1	(Reserved)	(Always ON)	-
SW 2	Baud rate	See table	
SW 3			
SW 4	Stop bit	1 bit	2 bits
SW 5	Gamma correction	See table	
SW 6			
SW 7	Half-toning mode	See table	
SW 8			

## Baud rate settings

Setting	SW 2	SW 3
19200 bps	OFF	OFF
9600 bps	ON	OFF
4800 bps	OFF	ON
2400 bps	ON	ON

*Gamma correction (ESC Z command)*

Setting	SW 5	SW 6
CRT Display A	OFF	OFF
CRT Display B	ON	OFF
Printer Output A	OFF	ON
Printer Output C	ON	ON

*Halftoning mode (ESC B command)*

Setting	SW 7	SW 8
Disabled	OFF	OFF
Halftoning mode A	ON	OFF
Halftoning mode B	OFF	ON
Halftoning mode C	ON	ON

## The Identity Data-Block

The GT-1000 sends the following data-block when it receives the **ESC I** (Request identity) command.

### Identity Data-Block

Order of bytes	Data (in hex)	Contents	Explanation
(Information block)			
1	02	STX code	Header: indicates the beginning of the data-block
2	xx*	Status	Status byte: indicates the status of the scanner and data
3	10	16 bytes	Byte counter: indicates the number of bytes of data
4	00		
(Data)			
1	42	"B"	Scanner indication (B2 level)
2	32	"2"	
3	52	"R"	Available resolution (50 dpi)
4	32	50	
5	00		
6	52	"R"	Available resolution (100 dpi)
7	64	100	
8	00		
9	52	"R"	Available resolution (200 dpi)
10	C8	200	
11	00		
12	41	"A"	Maximum reading area at the maximum resolution and 100% zoom (main scan 592 dots by sub scan 840 dots)
13	50	592	
14	02		
15	48	840	
16	03		

\*(xx denotes a variable)

## The Condition Data-Block

The GT-1000 sends the following data-block when it receives the **ESC S** (Request condition) command.

### Condition Data-Block

Order of bytes	Data (in hex)	Contents	Explanation
(Information block)			
1	02	STX code	Header: indicates the beginning of the data-block
2	xx*	Status	Status byte: indicates the status of the scanner
3	1B	27 Bytes	Byte counter: indicates the number of bytes of data
4	00		
(Data)			
1	43	"C"	Color mode
2	xx	i	
3	52	"R"	Resolution (main scan resolution)  (sub scan resolution)
4	xx	n1	
5	xx	n2	
6	xx		
7	xx		
8	41	"A"	Reading area (main scan offset length)  (sub scan offset length)  (main scan read length)  (sub scan read length)
9	xx	n1	
10	xx	n2	
11	xx		
12	xx	n3	
13	xx		
14	xx	n4	
15	xx		
16	xx		
17	44	"D"	Data format
18	xx	i	
19	42	"B"	Halftoning mode
20	xx	i	

Order of bytes	Data (in hex)	Contents	Explanation
21	4C	"L"	Brightness
22	xx	i	
23	5A	"Z"	Gamma correction
24	xx	i	
25	48	"H"	Zoom (main scan zoom)
26	xx	i1	
27	xx	12	

\*(xx denotes a variable)

---

## **GT-4000 Technical Data**

This appendix provides technical information that is relevant to software control of the EPSON GT-4000 color image scanner. For further details about this particular scanner model, see the GT-4000 user's guide.

### **Physical Characteristics**

Function level:	B3
Maximum reading area	214mm × 295mm
Effective pixels:	1712 × 2320 dots at 200 dpi, 100%
Standard interface:	RS-232C serial Bi-directional parallel
Optional interface:	SCSI
Serial interface protocols:	
Transfer rate:	300, 600, 1200, 2400, 4800, 9600, and 19200 bps
Stop bit:	2 bits and 1 bit
Parity check:	Odd, Even, None

### **Error Indications**

Scanner errors are displayed by the ZOOM indicator as shown below. The READY light remains on after a Command Error.

Error name	ZOOM indicator	READY light
Command Error	E-C	On
Interface Error	E-I	Off
Fatal Error	E-F (Flashes)	Off

## Software Functions and Settings

The function level of the GT-4000 is B3. The table below lists the functions and settings that can be controlled with software commands.

Function	Available settings
Output resolution	16 settings (50, 72, 80, 90, 100, 120, 144, 150, 160, 180, 200, 240, 300, 320, 360, and 400 dpi)
Zoom	50% to 200% in 1% increments
Reading area	1712 × 2320 dots at 200 dpi, 100%
Data format	1 to 8 bits per pixel per color
Color mode	color (page sequence, line sequence), monochrome (standard and with dropout color)
Brightness	7 levels
Halftoning mode	3 modes
Gamma correction	5 settings
Color correction	4 settings



## Software Defaults

With the DIP switches at the preset factory settings, the following values are the default values on the GT-4000 when the power is turned on.

Function	Command	Default value
Data format	ESC D	i=01 <sub>H</sub> (1 bit/pixel/color)
Resolution	ESC R	n1=100, n2=100 (dpi)
Zoom	ESC H	i1=100, i2=100 (%)
Reading area	ESC A	n1=0, n2=0, n3=856, n4=1160 (dot)
Color mode	ESC C	i=00 <sub>H</sub> (standard monochrome)
Brightness	ESCL	i=00 <sub>H</sub> (center)
Gamma correction	ESC Z	i=01 <sub>H</sub> (CRT Display A)
Halftoning mode	ESC B	i=00 <sub>H</sub> (Halftoning Mode A)
Color correction	ESC M	i=80 <sub>H</sub> (CRT Display)

**Note:**

*The default values for the **ESC B**, **ESC Z**, and **ESC M** commands are affected by DIP switch settings.*

# DIP Switch Setting

The GT-4000 has one bank of DIP switches on the control panel. The tables below show the function of each switch and the preset factory settings. The shaded boxes show the factory settings.

## DIP switch 1 settings

Switch No.	Function	ON	OFF
SW 1-1	Baud rate	See table	
SW 1-2			
SW 1-3			
SW 1-4	Stop bit	2 bits	1 bit
SW 1-5	Parity bit	Even	Odd
SW 1-6	Parity check	Enabled	Disabled
SW 1-7	Printer type for direct printing	See table	
SW 1-8			

## Baud rate settings

Setting	SW 1-1	SW 1-2	SW 1-3
19200 bps	OFF	OFF	OFF
9600 bps	ON	OFF	OFF
4800 bps	OFF	ON	OFF
2400 bps	ON	ON	OFF
1200 bps	OFF	OFF	ON
600 bps	ON	OFF	ON
300 bps	OFF	ON	ON

### Printer type for direct printing

Printer type	SW 1-7	SW 1-8
EPSON 24-pin color printer	OFF	OFF

### Note:

No other combination of SW 1-7 and SW 1-8 should be made. Direct printing is available only when the GT-4000 is directly connected to a printer through the parallel interface. This function has no relation to ordinary software controls. See the GT-4000 user's guide for further details.

### DIP switch 2 settings

Switch No.	Function	ON	OFF
SW 2-1	Halftoning mode	See table	
SW 2-2			
SW 2-3	Gamma correction	See table	
SW 2-4			
SW 2-5			
SW 2-6	Color correction	See table	
SW 2-7			
SW 2-8	(Reserved)	-	Always OFF

### Halftoning mode (ESC B command)

Setting	SW 2-1	SW 2-2
Disabled	OFF	OFF
Halftoning mode A	ON	OFF
Halftoning mode B	OFF	ON
Halftoning mode C	ON	ON

*Gamma correction (ESC Z command)*

Setting	SW 2-3	SW 2-4	SW 2-5
CRT Display A	OFF	OFF	OFF
CRT Display B	ON	OFF	OFF
Printer Output A	OFF	ON	OFF
Printer Output B	ON	ON	OFF
Printer Output C	OFF	OFF	ON

*Color correction (ESC M command)*

Setting	SW 2-6	SW 2-7
Impact dot matrix printer	OFF	OFF
Thermal transfer printer	ON	OFF
Ink jet printer	OFF	ON
CRT Display	ON	ON

## The Identity Data-Block

The GT-4000 sends the following data-block when it receives the **ESC I** (Request identity) command.

### Identity Data-Block

Order of bytes	Data (in hex)	Contents	Explanation
(Information block)			
1	02	STX code	Header: indicates the beginning of the data-block
2	xx*	Status	Status byte: indicates the status of the scanner and data
3	37	55 bytes	Byte counter: indicates the number of bytes of data
4	00		
(Data)			
1	42	"B"	Scanner indication (B3 level)
2	33	"3"	
3	52	"R"	Available resolution (50 dpi)
4	32	50	
5	00		
6	52	"R"	Available resolution (72 dpi)
7	48	72	
8	00		
9	52	"R"	Available resolution (80 dpi)
10	50	80	
11	00		
12	52	"R"	Available resolution (90 dpi)
13	5A	90	
14	00		
15	52	"R"	Available resolution (100 dpi)
16	64	100	
17	00		

Order of bytes	Data (in hex)	Contents	Explanation
18	52	"R"	Available resolution (120 dpi)
19	78	120	
20	00		
21	52	"R"	Available resolution (144 dpi)
22	90	144	
23	00		
24	52	"R"	Available resolution (150 dpi)
25	96	150	
26	00		
27	52	"R"	Available resolution (160 dpi)
28	A0	160	
29	00		
30	52	"R"	Available resolution (180 dpi)
31	B4	180	
32	00		
33	52	"R"	Available resolution (200 dpi)
34	C8	200	
35	00		
36	52	"R"	Available resolution (240 dpi)
37	F0	240	
38	00		
39	52	"R"	Available resolution (300 dpi)
40	2C	300	
41	01		
42	52	"R"	Available resolution (320 dpi)
43	40	320	
44	01		
45	52	"R"	Available resolution (360 dpi)
46	68	360	
47	01		

Order of bytes	Data (in hex)	Contents	Explanation
48	52	"R"	Available resolution (400 dpi)
49	90	400	
50	01		
51	41	"A"	Maximum reading area at the maximum resolution and 100% zoom (main scan 3424 dots by sub scan 4640 dots)
52	60	3424	
53	0D		
54	20	4640	
55	12		

\*(xx denotes a variable)

## The Condition Data-Block

The GT-4000 sends the following data-block when it receives the **ESC S** (Request condition) command.

### Condition Data-Block

Order of bytes	Data (in hex)	Contents	Explanation
(Information block)			
1	02	STX code	Header: indicates the beginning of the data-block
2	xx*	Status	Status byte: indicates the status of the scanner
3	1D	29 Bytes	Byte counter: indicates the number of bytes of data
4	00		
(Data)			
1	43	"C"	Color mode
2	xx	i	
3	52	"R"	Resolution (main scan resolution)
4	xx	n1	
5	xx		
6	xx	n2	(sub scan resolution)
7	xx		
8	41	"A"	Reading area

Order of bytes	Data (in hex)	Contents	Explanation	
9	xx	n1	(main scan offset length)	
10	xx			
11	xx	n2	(sub scan offset length)	
12	xx			
13	xx	n3	(main scan read length)	
14	xx			
15	xx	n4	(sub scan read length)	
16	xx			
17	44	"D"	Data format	
18	xx	i		
19	42	"B"	Halftoning mode	
20	xx	i		
21	4C	"L"	Brightness	
22	xx	i		
23	5A	"Z"	Gamma correction	
24	xx	i		
25	48	"H"	Zoom	
26	xx	i1		(main scan zoom)
27	xx	12		(sub scan zoom)
28	4D	"M"	Color correction	
29	xx	i		

\*(xx denotes a variable)



---

## **GT-6000 (ES-300C) Technical Data**

This appendix provides technical information that is relevant to software control of the EPSON GT-6000 color image scanner. For further details about this particular scanner model, see the GT-6000 user's guide.

### **Note for American and Canadian users:**

*The EPSON GT-6000 scanner is sold under the model name ES-300C in the United States and Canada. Therefore all the GT-6000 information in this guide applies to the ES-300C as well.*

## **Physical Characteristics**

Function level:	B3
Maximum reading area	216mm × 297mm
Effective pixels:	2552 × 3508 dots at 300 dpi, 100%
Standard interface:	RS-232C serial Bi-directional parallel
Optional interface:	SCSI
Serial interface protocols:	
Transfer rate:	300, 600, 1200, 2400, 4800, 9600, and 19200 bps
Stop bit:	2 bits and 1 bit
Parity check:	Odd, Even, None

## **Error Indications**

Scanner errors are displayed by the digital indicator as shown below. The READY light remains on after a Command Error.

Error name	Digital indicator	READY light
Command Error	E-C	On
Interface Error	E-I	Off
Fatal Error	E-F (Flashes)	Off

## Software Functions and Settings

The function level of the GT-6000 is B3. The table below lists the functions and settings that can be controlled with software commands.

Function	Available settings
Output resolution	19 settings (50, 72, 75, 80, 90, 100, 120, 144, 150, 160, 180, 200, 240, 300, 320, 360, 400, 480, and 600 dpi)
Zoom	50% to 200% in 1% increments
Reading area	2552 × 3508 dots at 300 dpi, 100%
Data format	1 to 8 bits per pixel per color
Color mode	color (page sequence, line sequence), monochrome (standard and with dropout color)
Brightness	7 levels
Halftoning mode	3 modes
Gamma correction	5 settings
Color correction	4 settings

## Software Defaults

With the DIP switches at the preset factory settings, the following values are the default values on the GT-6000 when the power is turned on.

Function	Command	Default value
Data format	ESC D	i=01 <sub>H</sub> (1 bit/pixel/color)
Resolution	ESC R	n1=100, n2=100 (dpi)
Zoom	ESC H	i1=100, i2=100 (%)
Reading area	ESC A	n1=0, n2=0, n3=848, n4=1169 (dot)
Color mode	ESC C	i=00 <sub>H</sub> (standard monochrome)
Brightness	ESC L	i=00 <sub>H</sub> (center)
Gamma correction	ESC Z	i=01 <sub>H</sub> (CRT Display A)
Halftoning mode	ESC B	i=00 <sub>H</sub> (Halftoning Mode A)
Color correction	ESC M	i=80 <sub>H</sub> (CRT Display)

**Note:**

*The default values for the **ESC B**, **ESC Z**, and **ESC M** commands are affected by DIP switch settings.*

# DIP Switch Setting

The GT-6000 has one bank of DIP switches on the control panel. The tables below show the function of each switch and the preset factory settings. The shaded boxes show the factory settings.

## DIP switch 1 settings

Switch No.	Function	ON	OFF
SW 1-1	Baud rate	See table	
SW 1-2			
SW 1-3			
SW 1-4	Stop bit	2 bits	1 bit
SW 1-5	Parity bit	Even	Odd
SW 1-6	Parity check	Enabled	Disabled
SW 1-7	Printer type for direct printing	See table	
SW 1-8			

## Baud rate settings

Setting	SW 1-1	SW 1-2	SW 1-3
19200 bps	OFF	OFF	OFF
9600 bps	ON	OFF	OFF
4800 bps	OFF	ON	OFF
2400 bps	ON	ON	OFF
1200 bps	OFF	OFF	ON
600 bps	ON	OFF	ON
300 bps	OFF	ON	ON
SCSI/Macintosh Plus	ON	ON	ON

### *Printer type for direct printing*

Printer type	SW 1-7	SW 1-8
EPSON 24-pin color printer (80 col.)	OFF	OFF
HP PaintJet color printer (parallel)	ON	OFF
EPSON 24-pin color printer (136 col.)	ON	ON

### **Note:**

*To use the direct printing function, SW 2-8 should also be set to ON.*

*No other combination of SW 1-7 and SW 1-8 should be made.*

*Direct printing is available only when the GT-6000 is directly connected to a printer through the parallel interface. This function has no relation to ordinary software controls. See the GT-6000 user's guide for further details.*

### **DIP switch 2 settings**

Switch No.	Function	ON	OFF
SW 2-1	Halftoning mode	See table	
SW 2-2			
SW 2-3	Gamma correction	See table	
SW 2-4			
SW 2-5			
SW 2-6	Color correction	See table	
SW 2-7			
SW 2-8	Parallel Interface direction	Uni-d	Bi-d

### **Note:**

*SW 2-8 should be set to OFF for normal scanner operation. This switch should be set to ON only when the direct printing function is used.*

*Halftoning mode (ESC B command)*

Setting	SW 2-1	SW 2-2
Disabled	OFF	OFF
Halftoning mode A	ON	OFF
Halftoning mode B	OFF	ON
Halftoning mode C	ON	ON

*Gamma correction (ESC Z command)*

Setting	SW 2-3	SW 2-4	SW 2-5
CRT Display A	OFF	OFF	OFF
CRT Display B	ON	OFF	OFF
Printer Output A	OFF	ON	OFF
Printer Output B	ON	ON	OFF
Printer Output C	OFF	OFF	ON

*Color correction (ESC M command)*

Setting	SW 2-6	SW 2-7
Impact dot matrix printer	OFF	OFF
Thermal transfer printer	ON	OFF
Ink jet printer	OFF	ON
CRT Display	ON	ON

## The Identity Data-Block

The GT-6000 sends the following data-block when it receives the **ESC I** (Request identity) command.

### Identity Data-Block

Order of bytes	Data (in hex)	Contents	Explanation
(Information block)			
1	02	STX code	Header: indicates the beginning of the data-block
2	xx*	Status	Status byte: indicates the status of the scanner and data
3	37	55 bytes	Byte counter: indicates the number of bytes of data
4	00		
(Data)			
1	42	"B"	Scanner indication (B3 level)
2	33	"3"	
3	52	"R"	Available resolution (50 dpi)
4	32	50	
5	00		
6	52	"R"	Available resolution (72 dpi)
7	48	72	
8	00		
9	52	"R"	Available resolution (75 dpi)
10	4B	75	
11	00		
12	52	"R"	Available resolution (80 dpi)
13	50	80	
14	00		
15	52	"R"	Available resolution (90 dpi)
16	5A	90	
17	00		

Order of bytes	Data (in hex)	Contents	Explanation
18	52	"R"	Available resolution (100 dpi)
19	64	100	
20	00		
21	52	"R"	Available resolution (120 dpi)
22	78	120	
23	00		
24	52	"R"	Available resolution (144 dpi)
25	90	144	
26	00		
27	52	"R"	Available resolution (150 dpi)
28	96	150	
29	00		
30	52	"R"	Available resolution (160 dpi)
31	A0	160	
32	00		
33	52	"R"	Available resolution (180 dpi)
34	B4	180	
35	00		
36	52	"R"	Available resolution (200 dpi)
37	C8	200	
38	00		
39	52	"R"	Available resolution (240 dpi)
40	F0	240	
41	00		
42	52	"R"	Available resolution (300 dpi)
43	2C	300	
44	01		
45	52	"R"	Available resolution (320 dpi)
46	40	320	
47	01		



Order of bytes	Data (in hex)	Contents	Explanation
48	52	"R"	Available resolution (360 dpi)
49	68	360	
50	01		
51	52	"R"	Available resolution (400 dpi)
52	90	400	
53	01		
54	52	"R"	Available resolution (480 dpi)
55	E0	480	
56	01		
57	52	"R"	Available resolution (600 dpi)
58	58	600	
59	02		
60	41	"A"	Maximum reading area at the maximum resolution and 100% zoom (main scan 5104 dots by sub scan 7016 dots)
61	F0	5104	
62	13		
63	68	7016	
64	1B		

\*(xx denotes a variable)

## The Condition Data-Block

The GT-6000 sends the following data-block when it receives the **ESC S** (Request condition) command.

### Condition Data-Block

Order of bytes	Data (in hex)	Contents	Explanation	
(Information block)				
1	02	STX code	Header: indicates the beginning of the data-block	
2	xx*	Status	Status byte: indicates the status of the scanner	
3	1D	29 Bytes	Byte counter: indicates the number of bytes of data	
4	00			
(Data)				
1	43	"C"	Color mode	
2	xx*	i		
3	52	"R"	Resolution (main scan resolution)  (sub scan resolution)	
4	xx	n1		
5	xx	n2		
6	xx			
7	xx			
8	41	"A"		Reading area (main scan offset length)  (sub scan offset length)  (main scan read length)  (sub scan read length)
9	xx	n1		
10	xx	n2		
11	xx			
12	xx	n3		
13	xx			
14	xx	n4		
15	xx			
16	xx			
17	44	"D"	Data format	
18	xx	i		
19	42	"B"	Halftoning mode	
20	xx	i		

Order of bytes	Data (in hex)	Contents	Explanation
21	4C	"L"	Brightness
22	xx	i	
23	5A	"Z"	Gamma correction
24	xx	i	
25	48	"H"	Zoom (main scan zoom) (sub scan zoom)
26	xx	i1	
27	xx	12	
28	4D	"M"	Color correction
29	xx	i	

\*(xx denotes a variable)

---

## **GT-6500 (ES-600C) Technical Data**

This appendix provides technical information that is relevant to software control of the EPSON GT-6500 color image scanner. For further details about this particular scanner model, see the GT-6500 user's guide.

### **Note for American and Canadian users:**

*The EPSON GT-6500 scanner is sold under the model name ES-600C in the United States and Canada. Software information in this guide refers to both the GT-6500 and ES-600C. The few hardware differences are described in this section when necessary.*

## **Physical Characteristics**

Function level:	B4
Maximum reading area	216mm × 297mm
Effective pixels:	2544 × 3510 dots at 300 dpi, 100%
Standard interface:*	RS-232D serial Bi-directional parallel or SCSI
Serial interface protocols:	
Transfer rate:	300, 600, 1200, 2400, 4800, 9600, and 19200 bps
Stop bit:	2 bits and 1 bit
Parity check:	Odd, Even, None
Options:	ADF, Transparency unit

### **\*Note:**

- ❑ *The GT-6500 comes in two versions: one version with SCSI standard, the other version with both the RS-232D serial and bi-directional parallel interfaces standard.*
- ❑ *The ES-600C comes in two versions: one version with SCSI standard, the other version with the bi-directional parallel interface standard.*

## **Error Indications**

The error indications are different for the GT-6500 and the ES-600C. Both versions are listed below.

### **GT-6500**

Scanner errors are displayed by the digital indicator as shown below. The READY light remains on after a Command Error.

Error name	Digital indicator	READY light
Command Error	E-C	On
Interface Error	E-I	Off
Fatal Error	E-F (Flashes)	Off
Option Error	E-O	Off

### **ES-600C**

Scanner errors are displayed on the control panel by a combination of the ERROR and READY lights as shown below.

Error name	ERROR light	READY light
Command Error	On	On
Interface Error	Blinks	Off
Fatal Error	Blinks	Blinks
Option Error	Off	Off

## Software Functions and Settings

The function level of the GT-6500 is B4. The table below lists the functions and settings that can be controlled with software commands.

Function	Available settings
Output resolution	23 settings (50, 60, 72, 75, 80, 90, 100, 120, 133, 144, 150, 160, 175, 180, 200, 216, 240, 300, 320, 360, 400, 480, and 600 dpi)
Zoom	50% to 200% in 1% increments
Reading area	2544 × 3510 dots at 200 dpi, 100%
Data format	1 to 8 bits per pixel per color
Color mode	color (page sequence, line sequence), monochrome (standard and with dropout color)
Brightness	7 levels
Halftoning mode	7 modes + user defined
Gamma correction	5 settings + user defined
Color correction	4 settings + user defined
Sharpness	5 settings
Scanning mode	Normal, high speed

## Software Defaults

With the DIP switches at the preset factory settings, the following values are the default values on the GT-6500 when the power is turned on.

Function	Command	Default value
Data format	ESC D	i=01 <sub>H</sub> (1 bit/pixel/color)
Resolution	ESC R	n1=100, n2=100 (dpi)
Zoom	ESC H	i1=100, i2=100 (%)
Reading area	ESC A	n1=0, n2=0, n3=848, n4=1170 (dot)
Color mode	ESC C	i=00 <sub>H</sub> (standard monochrome)
Brightness	ESC L	i=00 <sub>H</sub> (center)
Gamma correction	ESC Z	i=01 <sub>H</sub> (CRT Display A)
Halftoning mode	ESC B	i=00 <sub>H</sub> (Halftoning Mode A)
Color correction	ESC M	i=80 <sub>H</sub> (CRT Display)
Sharpness	ESC Q	i=00 <sub>H</sub> (Normal)
Scanning mode	ESC g	i=00 <sub>H</sub> (Normal mode)

**Note:**

The GT-6500 default values for the **ESC B**, **ESC Z**, and **ESC M** commands are affected by DIP switch settings.

# DIP Switch Setting

The DIP switch settings are different for the GT-6500 and ES-600C. Both versions are listed below.

## GT-6500

The GT-6500 has two banks of DIP switches on the front of the scanner. The tables below show the function of each switch and the preset factory settings. The shaded boxes show the factory settings.

### DIP switch 1 settings

Switch No.	Function	ON	OFF
SW 1-1	Baud rate	See table	
SW 1-2			
SW 1-3			
SW 1-4	Stop bit	2 bits	1 bit
SW 1-5	Parity bit	Even	Odd
SW 1-6	Parity check	Enabled	Disabled
SW 1-7	Printer type for direct printing	See table	
SW 1-8			



### *Baud rate settings*

Setting	SW 1-1	SW 1-2	SW 1-3
19200 bps	OFF	OFF	OFF
9600 bps	ON	OFF	OFF
4800 bps	OFF	ON	OFF
2400 bps	ON	ON	OFF
1200 bps	OFF	OFF	ON
600 bps	ON	OFF	ON
300 bps	OFF	ON	ON

### *Printer type for direct printing*

Printer type	SW 1-7	SW 1-8
EPSON 24-pin color printer (80 col.)	OFF	OFF
EPSON Stylus Color	ON	OFF
EPSON 24-pin color printer (136 col.)	ON	ON

### **Note:**

*To use the direct printing function, SW 2-8 should also be set to ON.*

*No other combination of SW 1-7 and SW 1-8 should be made.*

*Direct printing is available only when the GT-6500 is directly connected to a printer through the parallel interface. This function has no relation to ordinary software controls. See the GT-6500 user's guide for further details.*

## **DIP switch 2 settings**

Switch No.	Function	ON	OFF
SW 2-1	Half-toning mode	See table	
SW 2-2			
SW 2-3	Gamma correction	See table	
SW 2-4			
SW 2-5			
SW 2-6	Color correction	See table	
SW 2-7			
SW 2-8	GT-6000 emulation	ON	OFF

### *Half-toning mode (ESC B command)*

Setting	SW 2-1	SW 2-2
Disabled	OFF	OFF
Half-toning mode A	ON	OFF
Half-toning mode B	OFF	ON
Half-toning mode C	ON	ON

### *Gamma correction (ESC Z command)*

Setting	SW 2-3	SW 2-4	SW 2-5
CRT Display A	OFF	OFF	OFF
CRT Display B	ON	OFF	OFF
Printer Output A	OFF	ON	OFF
Printer Output B	ON	ON	OFF
Printer Output C	OFF	OFF	ON

### *Color correction (ESC M command)*

Setting	SW 2-6	SW 2-7
Impact dot matrix printer	OFF	OFF
Thermal transfer printer	ON	OFF
Ink jet printer	OFF	ON
CRT Display	ON	ON

## ES-600C

The ES-600C has one bank of DIP switches on the front of the scanner. The table below shows the function of each switch and the preset factory settings. The shaded boxes show the factory settings.

### *DIP switch 1 settings*

Switch No.	Function	ON	OFF
SW 1-1	Self test	ON	OFF
SW 1-2	Self test mode	Color	Monochrome
SW 1-3	Self test mode	Line	Page
SW 1-4	Not used	-	
SW 1-5	Not used	-	
SW 1-6	Not used	-	
SW 1-7	Not used	-	
SW 1-8	ES-600C emulation	ON	OFF

## The Identity Data-Block

The GT-6500 sends the following data-block when it receives the **ESC I** (Request identity) command.

### Identity Data-Block

Order of bytes	Data (in hex)	Contents	Explanation
(Information block)			
1	02	STX code	Header: indicates the beginning of the data-block
2	xx*	Status	Status byte: indicates the status of the scanner and data
3	4C	76 bytes	Byte counter: indicates the number of bytes of data
4	00		
(Data)			
1	42	"B"	Scanner indication (B4 level)
2	34	"4"	
3	52	"R"	Available resolution (50 dpi)
4	32	50	
5	00		
6	52	"R"	Available resolution (60 dpi)
7	3C	60	
8	00		
9	52	"R"	Available resolution (72 dpi)
10	48	72	
11	00		
12	52	"R"	Available resolution (75 dpi)
13	4B	75	
14	00		
15	52	"R"	Available resolution (80 dpi)
16	50	80	
17	00		

Order of bytes	Data (in hex)	Contents	Explanation
18	52	"R"	Available resolution (90 dpi)
19	5A	90	
20	00		
21	52	"R"	Available resolution (100 dpi)
22	64	100	
23	00		
24	52	"R"	Available resolution (120 dpi)
25	78	120	
26	00		
27	52	"R"	Available resolution (133 dpi)
28	85	133	
29	00		
30	52	"R"	Available resolution (144 dpi)
31	90	144	
32	00		
33	52	"R"	Available resolution (150 dpi)
34	96	150	
35	00		
36	52	"R"	Available resolution (160 dpi)
37	A0	160	
38	00		
39	52	"R"	Available resolution (175 dpi)
40	AF	175	
41	00		
42	52	"R"	Available resolution (180 dpi)
43	B4	180	
44	00		
45	52	"R"	Available resolution (200 dpi)
46	C8	200	
47	00		

Order of bytes	Data (in hex)	Contents	Explanation
48	52	"R"	Available resolution (216 dpi)
49	D8	216	
50	00		
51	52	"R"	Available resolution (240 dpi)
52	F0	240	
53	00		
54	52	"R"	Available resolution (300 dpi)
55	2C	300	
56	01		
57	52	"R"	Available resolution (320 dpi)
58	40	320	
59	01		
60	52	"R"	Available resolution (360 dpi)
61	68	360	
62	01		
63	52	"R"	Available resolution (400 dpi)
64	90	400	
65	01		
66	52	"R"	Available resolution (480 dpi)
67	E0	480	
68	01		
69	52	"R"	Available resolution (600 dpi)
70	58	600	
71	02		
72	41	"A"	Maximum reading area at the maximum resolution and 100% zoom (main scan 5100 dots by sub scan 7020 dots)
73	EC	5100	
74	13		
75	6C	7020	
76	1B		

\*(xx denotes a variable)

## The Condition Data-Block

The GT-6500 sends the following data-block when it receives the **ESC S** (Request condition) command.

### Condition Data-Block

Order of bytes	Data (in hex)	Contents	Explanation
(Information block)			
1	02	STX code	Header: indicates the beginning of the data-block
2	xx*	Status	Status byte: indicates the status of the scanner
3	21	33 Bytes	Byte counter: indicates the number of bytes of data
4	00		
(Data)			
1	43	"C"	Color mode
2	xx	i	
3	52	"R"	Resolution (main scan resolution)  (sub scan resolution)
4	xx	n1	
5	xx	n2	
6	xx		
7	xx		
8	41	"A"	Reading area (main scan offset length)  (sub scan offset length)  (main scan read length)  (sub scan read length)
9	xx	n1	
10	xx	n2	
11	xx		
12	xx	n3	
13	xx		
14	xx	n4	
15	xx		
16	xx		
17	44	"D"	Data format
18	xx	i	
19	42	"B"	Halftoning mode
20	xx	i	

Order of bytes	Data (in hex)	Contents	Explanation
21	4C	"L"	Brightness
22	xx	i	
23	5A	"Z"	Gamma correction
24	xx	i	
25	48	"H"	Zoom (main scan zoom) (sub scan zoom)
26	xx	i1	
27	xx	12	
28	4D	"M"	Color correction
29	xx	i	
30	51	"Q"	Sharpness
31	xx	i	
32	67	"g"	Scanning mode
33	xx	i	

\*(xx denotes a variable)



---

## **GT-8000 (ES-800C) Technical Data**

This appendix provides technical information that is relevant to software control of the EPSON GT-8000 color image scanner. For further details about this particular scanner model, see the GT-8000 user's guide.

### **Note for American and Canadian users:**

*The EPSON GT-8000 scanner is sold under the model name ES-800C in the United States and Canada. Therefore all the GT-8000 information in this guide applies to the ES-800C as well.*

## **Physical Characteristics**

Function level:	B4
Maximum reading area	216mm × 297mm
Effective pixels:	3400 × 4680 dots at 400 dpi, 100%
Standard interface:	Bi-directional parallel, SCSI
Option:	ADF, Transparency unit

## **Error Indications**

Scanner errors are displayed on the control panel by a combination of the ERROR and READY lights as shown below.

Error name	ERROR light	READY light
Command Error	On	On
Interface Error	Flashes	Off
Fatal Error	Flashes	Flashes
Option Error	Off	Off

## Software Functions and Settings

The function level of the GT-8000 is B4. The table below lists the functions and settings that can be controlled with software commands.

Function	Available settings
Output resolution	24 settings (50, 60, 72, 75, 80, 90, 100, 120, 133, 144, 150, 160, 175, 180, 200, 216, 240, 300, 320, 360, 400, 480, 600, and 800 dpi)
Zoom	50% to 200% in 1% increments
Reading area	3400 × 4680 dots at 400 dpi, 100%
Data format	1 to 8 bits per pixel per color
Color mode	color (page sequence, line sequence), monochrome (standard and with dropout color)
Brightness	7 levels
Halftoning mode	7 modes + userdefined
Gamma correction	5 settings + userdefined
Color correction	4 settings + userdefined
Sharpness	5 settings
Scanning mode	Normal, high speed

## Software Defaults

The following values are the default values on the GT-8000 when the power is turned on.

Function	Command	Default value
Data format	ESC D	i=01 <sub>H</sub> (1 bit/pixel/color)
Resolution	ESC R	n1=100, n2=100 (dpi)
Zoom	ESC H	i1=100, i2=100 (%)
Reading area	ESC A	n1=0, n2=0, n3=848, n4=1170 (dot)
Color mode	ESC C	i=00 <sub>H</sub> (standard monochrome)
Brightness	ESC L	i=00 <sub>H</sub> (center)
Gamma correction	ESC Z	i=01 <sub>H</sub> (CRT Display A)
Halftoning mode	ESC B	i=00 <sub>H</sub> (Halftoning Mode A)
Color correction	ESC M	i=80 <sub>H</sub> (CRT Display)
Sharpness	ESC Q	i=00 <sub>H</sub> (Normal)
Scanning mode	ESC g	i=00 <sub>H</sub> (Normal mode)

## The Identity Data-Block

The GT-8000 sends the following data-block when it receives the **ESC I** (Request identity) command.

### Identity Data-Block

Order of bytes	Data (in hex)	Contents	Explanation
(Information block)			
1	02	STX code	Header: indicates the beginning of the data-block
2	xx*	Status	Status byte: indicates the status of the scanner and data
3	4F	79 bytes	Byte counter: indicates the number of bytes of data
4	00		
(Data)			
1	42	"B"	Scanner indication (B4 level)
2	34	"4"	
3	52	"R"	Available resolution (50 dpi)
4	32	50	
5	00		
6	52	"R"	Available resolution (60 dpi)
7	3C	60	
8	00		
9	52	"R"	Available resolution (72 dpi)
10	48	72	
11	00		
12	52	"R"	Available resolution (75 dpi)
13	4B	75	
14	00		
15	52	"R"	Available resolution (80 dpi)
16	50	80	
17	00		
18	52	"R"	Available resolution (90 dpi)
19	5A	90	
20	00		

Order of bytes	Data (in hex)	Contents	Explanation
21	52	"R"	Available resolution (100 dpi)
22	64	100	
23	00		
24	52	"R"	Available resolution (120 dpi)
25	78	120	
26	00		
27	52	"R"	Available resolution (133 dpi)
28	85	133	
29	00		
30	52	"R"	Available resolution (144 dpi)
31	90	144	
32	00		
33	52	"R"	Available resolution (150 dpi)
34	96	150	
35	00		
36	52	"R"	Available resolution (160 dpi)
37	A0	160	
38	00		
39	52	"R"	Available resolution (175 dpi)
40	AF	175	
41	00		
42	52	"R"	Available resolution (180 dpi)
43	B4	180	
44	00		
45	52	"R"	Available resolution (200 dpi)
46	C8	200	
47	00		
48	52	"R"	Available resolution (216 dpi)
49	D8	216	
50	00		

Order of bytes	Data (in hex)	Contents	Explanation
51	52	"R"	Available resolution (240 dpi)
52	F0	240	
53	00		
54	52	"R"	Available resolution (300 dpi)
55	2C	300	
56	01		
57	52	"R"	Available resolution (320 dpi)
58	40	320	
59	01		
60	52	"R"	Available resolution (360 dpi)
61	68	360	
62	01		
63	52	"R"	Available resolution (400 dpi)
64	90	400	
65	01		
66	52	"R"	Available resolution (480 dpi)
67	E0	480	
68	01		
69	52	"R"	Available resolution (600 dpi)
70	58	600	
71	02		
72	52	"R"	Available resolution (800 dpi)
73	20	800	
74	03		
75	41	"A"	Maximum reading area at the maximum resolution and 100% zoom (main scan 6800 dots by sub scan 9360 dots)
76	90	6800	
77	1A		
78	90	9360	
79	24		

\*(xx denotes a variable)

## The Condition Data-Block

The GT-8000 sends the following data-block when it receives the **ESC S** (Request condition) command.

### Condition Data-Block

Order of bytes	Data (in hex)	Contents	Explanation
(Information block)			
1	02	STX code	Header: indicates the beginning of the data-block
2	xx*	Status	Status byte: indicates the status of the scanner
3	21	33 Bytes	Byte counter: indicates the number of bytes of data
4	00		
(Data)			
1	43	"C"	Color mode
2	xx	i	
3	52	"R"	Resolution (main scan resolution)  (sub scan resolution)
4	xx	n1	
5	xx	n2	
6	xx		
7	xx		
8	41	"A"	Reading area (main scan offset length)  (sub scan offset length)  (main scan read length)  (sub scan read length)
9	xx	n1	
10	xx	n2	
11	xx		
12	xx	n3	
13	xx		
14	xx	n4	
15	xx		
16	xx		
17	44	"D"	Data format
18	xx	i	
19	42	"B"	Half-toning mode
20	xx	i	

Order of bytes	Data (in hex)	Contents	Explanation
21	4C	"L"	Brightness
22	xx	i	
23	5A	"Z"	Gamma correction
24	xx	i	
25	48	"H"	Zoom (main scan zoom) (sub scan zoom)
26	xx	i1	
27	xx	12	
28	4D	"M"	Color correction
29	xx	i	
30	51	"Q"	Sharpness
31	xx	i	
32	67	"g"	Scanning mode
33	xx	i	

\*(xx denotes a variable)



---

## **GT-8500 (ES-1000C) Technical Data**

This appendix provides technical information that is relevant to software control of the EPSON GT-8500 color image scanner. For further details about this particular scanner model, see the GT-8500 user's guide.

### **Note for American and Canadian users:**

*The EPSON GT-8500 scanner is sold under the model name ES-1000C in the United States and Canada. Therefore all the GT-8500 information in this guide applies to the ES-1000C as well.*

## **Physical Characteristics**

Function level:	B5
Maximum reading area	216mm × 297mm
Effective pixels:	3400 × 4680 dots at 400 dpi, 100%
Standard interface:	Bi-directional parallel, SCSI
Option:	ADF, Transparency unit

## **Error Indications**

Scanner errors are displayed on the control panel by a combination of the ERROR and READY lights as shown below.

Error name	ERROR light	READY light
Command Error	On	On
Interface Error	Flashes	Off
Fatal Error	Flashes	Flashes
Option Error	Off	Off

## Software Functions and Settings

The function level of the GT-8500 is B5. The table below lists the functions and settings that can be controlled with software commands.

Function	Available settings
Output resolution	50 dpi to 1600 dpi in 1 dpi increments
Zoom	50% to 200% in 1% increments
Reading area	3400 × 4680 dots at 400 dpi, 100%
Data format	1 to 8 bits per pixel per color
Color mode	color (page sequence, line sequence, and byte sequence), monochrome (standard and with dropout color)
Brightness	7 levels
Halftoning mode	7 modes + userdefined
Gamma correction	5 settings + userdefined
Color correction	4 settings + userdefined
Sharpness	5 settings
Scanning mode	Normal, high speed

## Software Defaults

The following values are the default values on the GT-8500 when the power is turned on.

Function	Command	Default value
Data format	ESC D	i=01 <sub>H</sub> (1 bit/pixel/color)
Resolution	ESC R	n1=100, n2=100 (dpi)
Zoom	ESC H	i1=100, i2=100 (%)
Reading area	ESC A	n1=0, n2=0, n3=848, n4=1170 (dot)
Color mode	ESC C	i=00 <sub>H</sub> (standard monochrome)
Brightness	ESCL	i=00 <sub>H</sub> (center)
Gamma correction	ESC Z	i=01 <sub>H</sub> (CRT Display A)
Halftoning mode	ESC B	i=00 <sub>H</sub> (Halftoning Mode A)
Color correction	ESC M	i=80 <sub>H</sub> (CRT Display)
Sharpness	ESC Q	i=00 <sub>H</sub> (Normal)
Scanning mode	ESC g	i=00 <sub>H</sub> (Normal mode)
Set data order	ESC K	i=00 <sub>H</sub> (Left top first)

## The Identity Data-Block

The GT-8500 sends the following data-block when it receives the **ESC I** (Request identity) command.

### Identity Data-Block

Order of bytes	Data (in hex)	Contents	Explanation
(Information block)			
1	02	STX code	Header: indicates the beginning of the data-block
2	xx*	Status	Status byte: indicates the status of the scanner and data
3	58	88 bytes	Byte counter: indicates the number of bytes of data
4	00		
(Data)			
1	42	"B"	Scanner indication (B5 level)
2	35	"5"	
3	52	"R"	Available resolution (50 dpi)
4	32	50	
5	00		
6	52	"R"	Available resolution (60 dpi)
7	3C	60	
8	00		
9	52	"R"	Available resolution (72 dpi)
10	48	72	
11	00		
12	52	"R"	Available resolution (75 dpi)
13	4B	75	
14	00		
15	52	"R"	Available resolution (80 dpi)
16	50	80	
17	00		
18	52	"R"	Available resolution (90 dpi)
19	5A	90	
20	00		

Order of bytes	Data (in hex)	Contents	Explanation
21	52	"R"	Available resolution (100 dpi)
22	64	100	
23	00		
24	52	"R"	Available resolution (120 dpi)
25	78	120	
26	00		
27	52	"R"	Available resolution (133 dpi)
28	85	133	
29	00		
30	52	"R"	Available resolution (144 dpi)
31	90	144	
32	00		
33	52	"R"	Available resolution (150 dpi)
34	96	150	
35	00		
36	52	"R"	Available resolution (160 dpi)
37	A0	160	
38	00		
39	52	"R"	Available resolution (175 dpi)
40	AF	175	
41	00		
42	52	"R"	Available resolution (180 dpi)
43	B4	180	
44	00		
45	52	"R"	Available resolution (200 dpi)
46	C8	200	
47	00		
48	52	"R"	Available resolution (216 dpi)
49	D8	216	
50	00		

Order of bytes	Data (in hex)	Contents	Explanation
51	52	"R"	Available resolution (240 dpi)
52	F0	240	
53	00		
54	52	"R"	Available resolution (300 dpi)
55	2C	300	
56	01		
57	52	"R"	Available resolution (320 dpi)
58	40	320	
59	01		
60	52	"R"	Available resolution (360 dpi)
61	68	360	
62	01		
63	52	"R"	Available resolution (400 dpi)
64	90	400	
65	01		
66	52	"R"	Available resolution (480 dpi)
67	E0	480	
68	01		
69	52	"R"	Available resolution (600 dpi)
70	58	600	
71	02		
72	52	"R"	Available resolution (800 dpi)
73	20	800	
74	03		
75	52	"R"	Available resolution (900 dpi)
76	84	900	
77	03		
78	52	"R"	Available resolution (1200 dpi)
79	B0	1200	
80	04		

Order of bytes	Data (in hex)	Contents	Explanation
81	52	"R"	Available resolution (1600 dpi)
82	40	1600	
83	06		
84	41	"A"	Maximum reading area at the maximum resolution and 100% zoom (main scan 13600 dots by sub scan 18720 dots)
85	20	13600	
86	35		
87	20	18720	
88	49		

\*(xx denotes a variable)

## The Condition Data-Block

The GT-8500 sends the following data-block when it receives the **ESC S** (Request condition) command.

### Condition Data-Block

Order of bytes	Data (in hex)	Contents	Explanation
(Information block)			
1	02	STX code	Header: indicates the beginning of the data-block
2	xx*	Status	Status byte: indicates the status of the scanner
3	23	35 Bytes	Byte counter: indicates the number of bytes of data
4	00		
(Data)			
1	43	"C"	Color mode
2	xx	i	
3	52	"R"	Resolution
4	xx	n1	(main scan resolution)
5	xx		
6	xx	n2	(sub scan resolution)
7	xx		

Order of bytes	Data (in hex)	Contents	Explanation
8	41	"A"	Reading area  (main scan offset length)  (sub scan offset length)  (main scan read length)  (sub scan read length)
9	xx	n1	
10	xx	n2	
11	xx		
12	xx	n3	
13	xx		
14	xx	n4	
15	xx		
16	xx		
17	44	"D"	Data format
18	xx	i	
19	42	"B"	Half-toning mode
20	xx	i	
21	4C	"L"	Brightness
22	xx	i	
23	5A	"Z"	Gamma correction
24	xx	i	
25	48	"H"	Zoom  (main scan zoom)  (sub scan zoom)
26	xx	i1	
27	xx	12	
28	4D	"M"	Color correction
29	xx	i	
30	51	"Q"	Sharpness
31	xx	i	
32	67	"g"	Scanning mode
33	xx	i	



Order of bytes	Data (in hex)	Contents	Explanation
34	4B	"K"	Data order
35	xx	i	

\*(xx denotes a variable)

---

## **GT-9000 (ES-1200C) Technical Data**

This appendix provides technical information that is relevant to software control of the EPSON GT-9000 color image scanner. For further details about this particular scanner model, see the GT-9000 user's guide.

### **Note for American and Canadian users:**

*The EPSON GT-9000 scanner is sold under the model name ES-1200C in the United States and Canada. Therefore all the GT-9000 information in this guide applies to the ES-1200C as well.*

## **Physical Characteristics**

Function level:	B4
Maximum reading area	216mm × 297mm
Effective pixels:	5096 × 7016 dots at 600 dpi, 100%
Standard interface:	Bi-directional parallel, SCSI
Option:	ADF, Transparency unit

## **Error Indications**

Scanner errors are displayed on the control panel by a combination of the ERROR and READY lights as shown below.

Error name	ERROR light	READY light
Command Error	On	On
Interface Error	Flashes	Off
Fatal Error	Flashes	Flashes
Option Error	Off	Off

## Software Functions and Settings

The function level of the GT-9000 is B4. The table below shows the list of the functions and settings that can be controlled with software commands.

Function	Available settings
Output resolution	29 settings (50, 60, 72, 75, 80, 90, 100, 120, 133, 144, 150, 160, 175, 180, 200, 216, 240, 300, 320, 360, 400, 480, 600, 800, 900, 1200, 1600, 1800, and 2400 dpi)
Zoom	50% to 200% in 1% increments
Reading area	5096 × 7016 dots at 600 dpi, 100%
Data format	1 to 8 bits per pixel per color
Color mode	color (page sequence, line sequence), monochrome (standard and with dropout color)
Brightness	7 levels
Halftoning mode	7 modes + userdefined
Gamma correction	5 settings + userdefined
Color correction	4 settings + userdefined
Sharpness	5 settings
Scanning mode	Normal, high speed

## Software Defaults

The following are the default values of the GT-9000 at power on.

Function	Command	Default value
Data format	ESC D	i=01 <sub>H</sub> (1 bit/pixel/color)
Resolution	ESC R	n1=100, n2=100 (dpi)
Zoom	ESC H	i1=100, i2=100 (%)
Reading area	ESC A	n1=0, n2=0, n3=848, n4=1170 (dot)
Color mode	ESC C	i=00 <sub>H</sub> (standard monochrome)
Brightness	ESC L	i=00 <sub>H</sub> (center)
Gamma correction	ESC Z	i=01 <sub>H</sub> (CRT Display A)
Halftoning mode	ESC B	i=00 <sub>H</sub> (Halftoning Mode A)
Color correction	ESC M	i=80 <sub>H</sub> (CRT Display)
Sharpness	ESC Q	i=00 <sub>H</sub> (Normal)
Scanning mode	ESC g	i=00 <sub>H</sub> (Normal mode)

## The Identity Data-Block

The GT-9000 sends the following data-block when it receives the **ESC I** (Request identity) command.

### Identity Data-Block

Order of bytes	Data (in hex)	Contents	Explanation
(Information block)			
1	02	STX code	Header: indicates the beginning of the data-block
2	xx*	Status	Status byte: indicates the status of the scanner and data
3	5E	94 bytes	Byte counter: indicates the number of bytes of data
4	00		
(Data)			
1	42	"B"	Scanner indication (B4 level)
2	35	"4"	
3	52	"R"	Available resolution (50 dpi)
4	32	50	
5	00		
6	52	"R"	Available resolution (60 dpi)
7	3C	60	
8	00		
9	52	"R"	Available resolution (72 dpi)
10	48	72	
11	00		
12	52	"R"	Available resolution (75 dpi)
13	4B	75	
14	00		
15	52	"R"	Available resolution (80 dpi)
16	50	80	
17	00		
18	52	"R"	Available resolution (90 dpi)
19	5A	90	
20	00		

Order of bytes	Data (in hex)	Contents	Explanation
21	52	"R"	Available resolution (100 dpi)
22	64	100	
23	00		
24	52	"R"	Available resolution (120 dpi)
25	78	120	
26	00		
27	52	"R"	Available resolution (133 dpi)
28	85	133	
29	00		
30	52	"R"	Available resolution (144 dpi)
31	90	144	
32	00		
33	52	"R"	Available resolution (150 dpi)
34	96	150	
35	00		
36	52	"R"	Available resolution (160 dpi)
37	A0	160	
38	00		
39	52	"R"	Available resolution (175 dpi)
40	AF	175	
41	00		
42	52	"R"	Available resolution (180 dpi)
43	B4	180	
44	00		
45	52	"R"	Available resolution (200 dpi)
46	C8	200	
47	00		
48	52	"R"	Available resolution (216 dpi)
49	D8	216	
50	00		

Order of bytes	Data (in hex)	Contents	Explanation
51	52	"R"	Available resolution (240 dpi)
52	F0	240	
53	00		
54	52	"R"	Available resolution (300 dpi)
55	2C	300	
56	01		
57	52	"R"	Available resolution (320 dpi)
58	40	320	
59	01		
60	52	"R"	Available resolution (360 dpi)
61	68	360	
62	01		
63	52	"R"	Available resolution (400 dpi)
64	90	400	
65	01		
66	52	"R"	Available resolution (480 dpi)
67	E0	480	
68	01		
69	52	"R"	Available resolution (600 dpi)
70	58	600	
71	02		
72	52	"R"	Available resolution (800 dpi)
73	20	800	
74	03		
75	52	"R"	Available resolution (900 dpi)
76	84	900	
77	03		
78	52	"R"	Available resolution (1200 dpi)
79	B0	1200	
80	04		

Order of bytes	Data (in hex)	Contents	Explanation
81	52	"R"	Available resolution (1600 dpi)
82	40	1600	
83	06		
84	52	"R"	Available resolution (1800 dpi)
85	08	1800	
86	07		
87	52	"R"	Available resolution (2400 dpi)
88	60	2400	
89	09		
90	41	"A"	Maximum reading area at the maximum resolution and 100% zoom (main scan 20400 dots by sub scan 28080 dots)
91	B0	20400	
92	4F		
93	B0	28080	
94	6D		

\*(xx denotes a variable)



## The Condition Data-Block

The GT-9000 sends the following data-block when it receives the **ESC S** (Request condition) command.

### Condition Data-Block

Order of bytes	Data (in hex)	Contents	Explanation
(Information block)			
1	02	STX code	Header: indicates the beginning of the data-block
2	xx*	Status	Status byte: indicates the status of the scanner
3	21	33 Bytes	Byte counter: indicates the number of bytes of data
4	00		
(Data)			
1	43	"C"	Color mode
2	xx*	i	
3	52	"R"	Resolution (main scan resolution)  (sub scan resolution)
4	xx	n1	
5	xx	n2	
6	xx		
7	xx		
8	41	"A"	Reading area (main scan offset length)  (sub scan offset length)  (main scan read length)  (sub scan read length)
9	xx	n1	
10	xx	n2	
11	xx		
12	xx	n3	
13	xx		
14	xx	n4	
15	xx		
16	xx		
17	44	"D"	Data format
18	xx	i	
19	42	"B"	Half-toning mode
20	xx	i	

Order of bytes	Data (in hex)	Contents	Explanation
21	4C	"L"	Brightness
22	xx	i	
23	5A	"Z"	Gamma correction
24	xx	i	
25	48	"H"	Zoom (main scan zoom) (sub scan zoom)
26	xx	i1	
27	xx	12	
28	4D	"M"	Color correction
29	xx	i	
30	51	"Q"	Sharpness
31	xx	i	
32	67	"g"	Scanning mode
33	xx	i	

\*(xx denotes a variable)

---

## **GT-5000 (Action Scanner II) Technical Data**

This appendix provides technical information that is relevant to software control of the EPSON GT-5000 color image scanner. For further details about this particular scanner model, see the GT-5000 user's guide.

### **Note for American and Canadian users:**

*The EPSON GT-5000 scanner is sold under the model name Action Scanner II in the United States and Canada. Therefore all the GT-5000 information in this guide applies to the Action Scanner II as well.*

## **Physical Characteristics**

Function level:	B5
Maximum reading area	216mm × 297mm
Effective pixels:	2550 × 3510 dots at 300 dpi, 100%
Standard interface:	Bi-directional parallel or SCSI
Option:	None

## **Error Indications**

Scanner errors are displayed on the control panel by a combination of the ERROR and READY lights as shown below.

Error name	ERROR light	READY light
Command Error	On	On
Interface Error	Flashes	Off
Fatal Error	Flashes	Flashes

## Software Functions and Settings

The function level of the GT-5000 is B5. The table below lists the functions and settings that can be controlled with software commands.

Function	Available settings
Output resolution	50 dpi to 1200 dpi in 1 dpi increments
Zoom	50% to 200% in 1% increments
Reading area	2550 × 3510 dots at 300 dpi, 100%
Data format	1 to 8 bits per pixel per color
Color mode	color (page sequence, line sequence, and byte sequence), monochrome (standard and with dropout color)
Brightness	7 levels
Halftoning mode	7 modes + userdefined
Gamma correction	5 settings + userdefined
Color correction	4 settings + userdefined
Sharpness	5 settings
Scanning mode	Normal, high speed

## Software Defaults

The following are the default values of the GT-5000 at power on.

Function	Command	Default value
Data format	ESC D	i=01 <sub>H</sub> (1 bit/pixel/color)
Resolution	ESC R	n1=100, n2=100 (dpi)
Zoom	ESC H	i1=100, i2=100 (%)
Reading area	ESC A	n1=0, n2=0, n3=848, n4=1170 (dot)
Color mode	ESC C	i=00 <sub>H</sub> (standard monochrome)
Brightness	ESC L	i=00 <sub>H</sub> (center)
Gamma correction	ESC Z	i=01 <sub>H</sub> (CRT Display A)
Halftoning mode	ESC B	i=01 <sub>H</sub> (Halftoning Mode A)
Color correction	ESC M	i=80 <sub>H</sub> (CRT Display)
Sharpness	ESC Q	i=00 <sub>H</sub> (Normal)
Scanning mode	ESC g	i=00 <sub>H</sub> (Normal mode)
Set data order	ESC K	i=00 <sub>H</sub> (Left top first)

## The Identity Data-Block

The GT-5000 sends the following data-block when it receives the **ESC I** (Request identity) command.

### Identity Data-Block

Order of bytes	Data (in hex)	Contents	Explanation
(Information block)			
1	02	STX code	Header: indicates the beginning of the data-block
2	xx*	Status	Status byte: indicates the status of the scanner and data
3	58	88 bytes	Byte counter: indicates the number of bytes of data
4	00		
(Data)			
1	42	"B"	Scanner indication (B5 level)
2	35	"5"	
3	52	"R"	Available resolution (50 dpi)
4	32	50	
5	00		
6	52	"R"	Available resolution (60 dpi)
7	3C	60	
8	00		
9	52	"R"	Available resolution (72 dpi)
10	48	72	
11	00		
12	52	"R"	Available resolution (75 dpi)
13	4B	75	
14	00		
15	52	"R"	Available resolution (80 dpi)
16	50	80	
17	00		
18	52	"R"	Available resolution (90 dpi)
19	5A	90	
20	00		

Order of bytes	Data (in hex)	Contents	Explanation
21	52	"R"	Available resolution (100 dpi)
22	64	100	
23	00		
24	52	"R"	Available resolution (120 dpi)
25	78	120	
26	00		
27	52	"R"	Available resolution (133 dpi)
28	85	133	
29	00		
30	52	"R"	Available resolution (144 dpi)
31	90	144	
32	00		
33	52	"R"	Available resolution (150 dpi)
34	96	150	
35	00		
36	52	"R"	Available resolution (160 dpi)
37	A0	160	
38	00		
39	52	"R"	Available resolution (175 dpi)
40	AF	175	
41	00		
42	52	"R"	Available resolution (180 dpi)
43	B4	180	
44	00		
45	52	"R"	Available resolution (200 dpi)
46	C8	200	
47	00		
48	52	"R"	Available resolution (216 dpi)
49	D8	216	
50	00		

Order of bytes	Data (in hex)	Contents	Explanation
51	52	"R"	Available resolution (240 dpi)
52	F0	240	
53	00		
54	52	"R"	Available resolution (300 dpi)
55	2C	300	
56	01		
57	52	"R"	Available resolution (320 dpi)
58	40	320	
59	01		
60	52	"R"	Available resolution (360 dpi)
61	68	360	
62	01		
63	52	"R"	Available resolution (400 dpi)
64	90	400	
65	01		
66	52	"R"	Available resolution (480 dpi)
67	E0	480	
68	01		
69	52	"R"	Available resolution (600 dpi)
70	58	600	
71	02		
72	52	"R"	Available resolution (720 dpi)
73	D0	720	
74	02		
75	52	"R"	Available resolution (800 dpi)
76	20	800	
77	03		
78	52	"R"	Available resolution (900 dpi)
79	84	900	
80	03		



Order of bytes	Data (in hex)	Contents	Explanation
81	52	"R"	Available resolution (1200 dpi)
82	B0	1200	
83	04		
84	41	"A"	Maximum reading area at the maximum resolution and 100% zoom (main scan 10200 dots by sub scan 14040 dots)
85	D8	10200	
86	27		
87	98	14040	
88	3A		

\*(xx denotes a variable)

## The Condition Data-Block

The GT-5000 sends the following data-block when it receives the **ESC S** (Request condition) command.

### Condition Data-Block

Order of bytes	Data (in hex)	Contents	Explanation
(Information block)			
1	02	STX code	Header: indicates the beginning of the data-block
2	xx*	Status	Status byte: indicates the status of the scanner
3	23	35 Bytes	Byte counter: indicates the number of bytes of data
4	00		
(Data)			
1	43	"C"	Color mode
2	xx	i	
3	52	"R"	Resolution
4	xx	n1	(main scan resolution)
5	xx		
6	xx	n2	(sub scan resolution)
7	xx		

Order of bytes	Data (in hex)	Contents	Explanation
8	41	"A"	Reading area  (main scan offset length)  (sub scan offset length)  (main scan read length)  (sub scan read length)
9	xx	n1	
10	xx		
11	xx	n2	
12	xx		
13	xx	n3	
14	xx		
15	xx	n4	
16	xx		
17	44	"D"	Data format
18	xx	i	
19	42	"B"	Half-toning mode
20	xx	i	
21	4C	"L"	Brightness
22	xx	i	
23	5A	"Z"	Gamma correction
24	xx	i	
25	48	"H"	Zoom  (main scan zoom)  (sub scan zoom)
26	xx	i1	
27	xx	12	
28	4D	"M"	Color correction
29	xx	i	
30	51	"Q"	Sharpness
31	xx	i	
32	67	"g"	Scanning mode
33	xx	i	

Order of bytes	Data (in hex)	Contents	Explanation
34	4B	"K"	Data order
35	xx	i	

\*(xx denotes a variable)

---

## **GT-300 (ES-300GS) Technical Data**

This appendix provides technical information that is relevant to software control of the EPSON GT-300 document scanner. For further details about this particular scanner model, see the GT-300 user's guide.

### **Note for American and Canadian users:**

*The EPSON GT-300 scanner is sold under the model name ES-300GS in the United States and Canada. Therefore all the GT-300 information in this guide applies to the ES-300GS as well.*

## **Physical Characteristics**

Function level:	A5
Maximum reading area	216mm × 355mm
Effective pixels:	2550 × 4200 dots at 300 dpi, 100%
Standard interface:	Bi-directional parallel or SCSI
Option:	None

## **Error Indications**

Scanner errors are displayed on the control panel by a combination of the ERROR and READY lights as shown below.

Error name	ERROR light	READY light
Command Error	On	On
Interface Error	Flashes	Off
Fatal Error	Flashes	Flashes

## Software Functions and Settings

The function level of the GT-300 is A5. The table below lists the functions and settings that can be controlled with software commands.

Function	Available settings
Output resolution	50 dpi to 600 dpi in 1 dpi increments
Zoom	50% to 200% in 1% increments
Reading area	2550 × 4200 dots at 300 dpi, 100%
Data format	1 to 8 bits per pixel per color
Color mode	monochrome (standard)
Brightness	7 levels
Halftoning mode	7 modes + userdefined
Gamma correction	5 settings + userdefined
Sharpness	5 settings
Scanning mode	Normal, high speed

## Software Defaults

The following values are the default values on the GT-300 when the power is turned on.

Function	Command	Default value
Data format	ESC D	i=01 <sub>H</sub> (1 bit/pixel)
Resolution	ESC R	n1=100, n2=100 (dpi)
Zoom	ESC H	i1=100, i2=100 (%)
Reading area	ESC A	n1=0, n2=0, n3=848, n4=1170 (dot)
Brightness	ESC L	i=00 <sub>H</sub> (center)
Gamma correction	ESC Z	i=01 <sub>H</sub> (CRT Display A)
Halftoning mode	ESC B	i=00 <sub>H</sub> (Halftoning Mode A)
Sharpness	ESC Q	i=00 <sub>H</sub> (Normal)
Scanning mode	ESC g	i=00 <sub>H</sub> (Normal mode)
Set data order	ESC K	i=00 <sub>H</sub> (Left top first)

## The Identity Data-Block

The GT-300 sends the following data-block when it receives the **ESC I** (Request identity) command.

### Identity Data-Block

Order of bytes	Data (in hex)	Contents	Explanation
(Information block)			
1	02	STX code	Header: indicates the beginning of the data-block
2	xx*	Status	Status byte: indicates the status of the scanner and data
3	4C	76 bytes	Byte counter: indicates the number of bytes of data
4	00		
(Data)			
1	41	"A"	Scanner indication A5 level
2	35	"5"	
3	52	"R"	Available resolution (50 dpi)
4	32	50	
5	00		
6	52	"R"	Available resolution (60 dpi)
7	3C	60	
8	00		
9	52	"R"	Available resolution (72 dpi)
10	48	72	
11	00		
12	52	"R"	Available resolution (75 dpi)
13	4B	75	
14	00		
15	52	"R"	Available resolution (80 dpi)
16	50	80	
17	00		
18	52	"R"	Available resolution (90 dpi)
19	5A	90	
20	00		

Order of bytes	Data (in hex)	Contents	Explanation
21	52	"R"	Available resolution (100 dpi)
22	64	100	
23	00		
24	52	"R"	Available resolution (120 dpi)
25	78	120	
26	00		
27	52	"R"	Available resolution (133 dpi)
28	85	133	
29	00		
30	52	"R"	Available resolution (144 dpi)
31	90	144	
32	00		
33	52	"R"	Available resolution (150 dpi)
34	96	150	
35	00		
36	52	"R"	Available resolution (160 dpi)
37	A0	160	
38	00		
39	52	"R"	Available resolution (175 dpi)
40	AF	175	
41	00		
42	52	"R"	Available resolution (180 dpi)
43	B4	180	
44	00		
45	52	"R"	Available resolution (200 dpi)
46	C8	200	
47	00		
48	52	"R"	Available resolution (216 dpi)
49	D8	216	
50	00		



Order of bytes	Data (in hex)	Contents	Explanation
51	52	"R"	Available resolution (240 dpi)
52	F0	240	
53	00		
54	52	"R"	Available resolution (300 dpi)
55	2C	300	
56	01		
57	52	"R"	Available resolution (320 dpi)
58	40	320	
59	01		
60	52	"R"	Available resolution (360 dpi)
61	68	360	
62	01		
63	52	"R"	Available resolution (400 dpi)
64	90	400	
65	01		
66	52	"R"	Available resolution (480 dpi)
67	E0	480	
68	01		
69	52	"R"	Available resolution (600 dpi)
70	58	600	
71	02		
72	41	"A"	Maximum reading area at the maximum resolution and 100% zoom (main scan 5100 dots by sub scan 8400 dots)
73	EC	5100	
77	13		
75	D0	8400	
76	20		

\*(xx denotes a variable)

## ***The Condition Data-Block***

The GT-300 sends the following data-block when it receives the **ESC S** (Request condition) command.

### Condition Data-Block

Order of bytes	Data (in hex)	Contents	Explanation
(Information block)			
1	02	STX code	Header: indicates the beginning of the data-block
2	xx*	Status	Status byte: indicates the status of the scanner
3	23	35 Bytes	Byte counter: indicates the number of bytes of data
4	00		
(Data)			
1	43	"C"	Color mode
2	xx	0	
3	52	"R"	Resolution
4	xx	n1	(main scan resolution)
5	xx		
6	xx	n2	(sub scan resolution)
7	xx		
8	41	"A"	Reading area
9	xx	n1	(main scan offset length)
10	xx		
11	xx	n2	(sub scan offset length)
12	xx		
13	xx	n3	(main scan read length)
14	xx		
15	xx	n4	(sub scan read length)
16	xx		
17	44	"D"	Data format
18	xx	i	
19	42	"B"	Halftoning mode
20	xx	i	
21	4C	"L"	Brightness
22	xx	i	
23	5A	"Z"	Gamma correction
24	xx	i	
25	48	"H"	Zoom

Order of bytes	Data (in hex)	Contents	Explanation
26	xx	i1	(main scan zoom) (sub scan zoom)
27	xx	12	
30	51	"Q"	Sharpness
31	xx	i	
32	67	"g"	Scanning mode
33	xx	i	
34	4B	"K"	Data order
35	xx	i	
36	73	"s"	Auto area segmentation
37	xx	i	

\*(xx denotes a variable)

